

**PRASA**

## *P* **PRASA - CARROCERIA**

- CIERRES
- CERROJOS
- ACCESORIOS PARA  
CONTENEDORES Y BASCULANTES
- MACHOS
- HEMBRAS
- PILARES Y CUÑAS DE LLANTA
- GANCHOS Y PRECINTOS
- BISAGRAS
- TORNOS
- ACCESORIOS VARIOS  
DE CARROCERIA
- ACCESORIOS AGRICOLAS

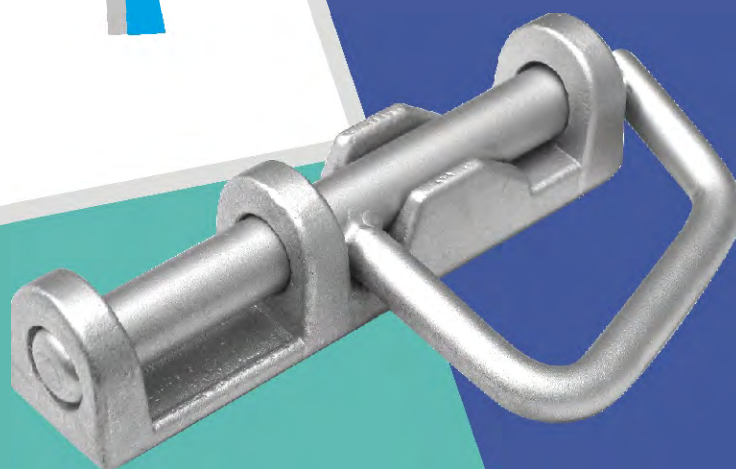

**PROVEEDORA ASTUR-ANDALUZA, S.L.**

## ÍNDICE

<i>CIERRES LATERALES</i>	1
<i>CIERRES TRASEROS</i>	3
<i>UÑAS DE FORJA FIJAS</i>	5
<i>UÑAS DE FORJA ARTICULADAS</i>	6
<i>CIERRES REGULABLES</i>	8
<i>CIERRES DE BULÓN</i>	11
<i>CIERRES DE CHAPA</i>	12
<i>UÑAS DE CHAPA</i>	14
<i>CERROJOS CON MUELLE</i>	17
<i>CIERRES DE ALUMINIO</i>	19
<i>CIERRES DE CAJÓN</i>	20
<i>CIERRES DE FALLEBA</i>	21
<i>CERROJOS</i>	23
<i>ACCE. PARA CONTENEDORES Y BASCULANTES</i>	24
<i>MACHOS</i>	28
<i>HEMBRAS</i>	29
<i>BISAGRAS COMPLETAS</i>	33
<i>BISAGRAS DE CHAPA</i>	37
<i>BISAGRAS DE LIBRO</i>	41
<i>ANILLAS</i>	44
<i>GANCHOS Y PRECINTOS</i>	45
<i>TORNOS TENSORES</i>	49
<i>SOPORTES DE CHASIS</i>	51
<i>PILARES CÓNICOS Y CUÑAS DE LLANTA</i>	53
<i>SOPORTES DE ALETA</i>	54
<i>SOPORTES DE RUEDA</i>	55
<i>RETENEDORES DE PUERTA</i>	56
<i>SISTEMAS DE CARGA</i>	57
<i>ESCALERAS</i>	58
<i>VARIOS CARROCERIA</i>	59
<i>ACCESORIOS AGRÍCOLAS</i>	63
<i>COMBINACIÓN DE PIEZAS</i>	67

Todas las medidas de este catálogo de muestras son aproximadas, la empresa se reserva el derecho de modificarlas sin previo aviso.

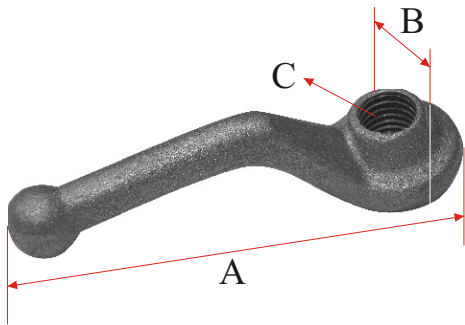

## CIERRE LATERAL

REF.	A (mm)	B (mm)	C (mm)
T-1 5/8"	123	39	5/8"
T-16	136	42	16
T-2 3/4"	136	42	3/4"
T-20	150	46	20
T-3 7/8"	150	46	7/8"
T-4 1"	154	46	1"

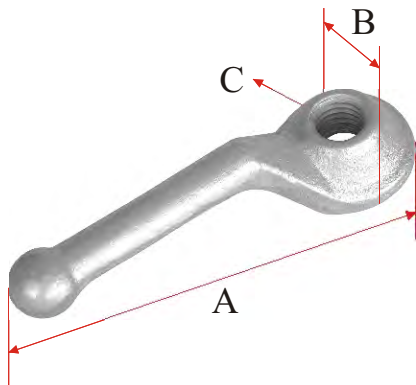

## CIERRE LATERAL

REF.	A (mm)	B (mm)	C (mm)
T-1 5/8" ZINC	123	39	5/8"
T-16 ZINC	136	42	16
T-2 3/4" ZINC	136	42	3/4"
T-20 ZINC	150	46	20
T-3 7/8" ZINC	150	46	7/8"
T-4 1" ZINC	154	46	1"

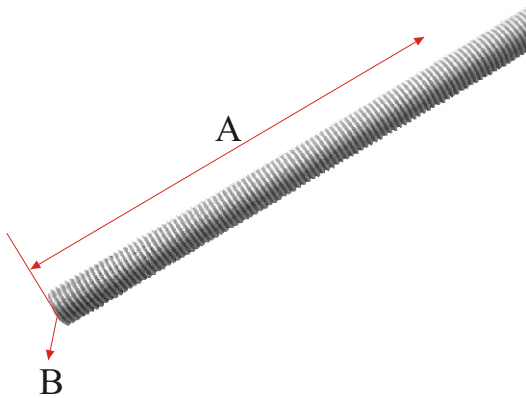

## CIERRE LATERALE

REF.	A (mm)	B (mm)
VR-1 5/8" ZINC	1000	5/8"
VR-16 ZINC	1000	16
VR-2 3/4" ZINC	1000	3/4"
VR-20 ZINC	1000	20
VR-3 7/8" ZINC	1000	7/8"
VR-4 1" ZINC	1000	1"

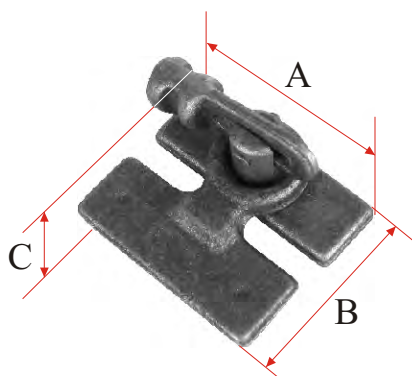

## CIERRE LATERAL

REF.	A (mm)	B (mm)	C (mm)
T-5	124	90	45
T-6	81	69	34

**CIERRE LATERAL**

REF.	A (mm)	B (mm)	C (mm)
T-5 ZINC	124	90	45
T-6 ZINC	81	69	34

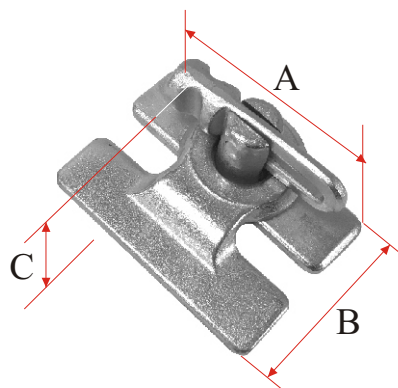
**CIERRE LATERAL**

REF.	A (mm)	B (mm)	C (mm)
T-8	370	42	25
T-9	290	34	20

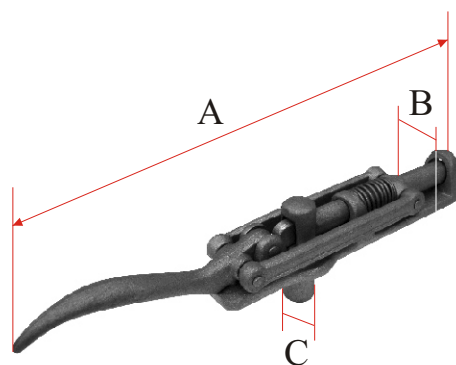

**CIERRE LATERAL**

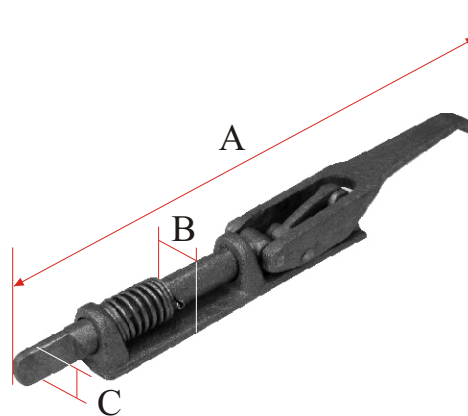
REF.	A (mm)	B (mm)	C (mm)
T-10	326	33	16

**CIERRE LATERAL**

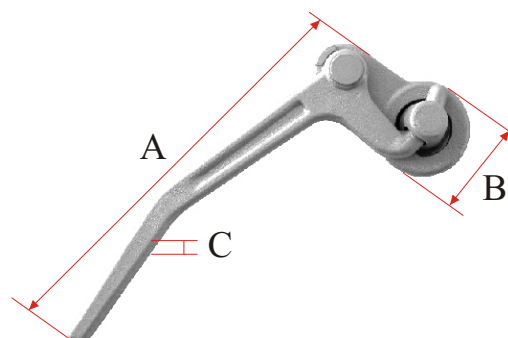
REF.	A (mm)	B (mm)	C (mm)
CBL-10 ZINC ( IZD. )	263	60	12
CBL-15 ZINC ( DCH. )	263	60	12

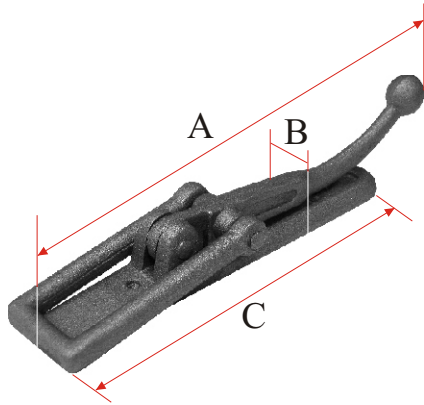



## CIERRE TRASERO

REF.	A (mm)	B (mm)	C (mm)
C-2	257	31	208
C-3	193	26	146
C-4	149	22	114

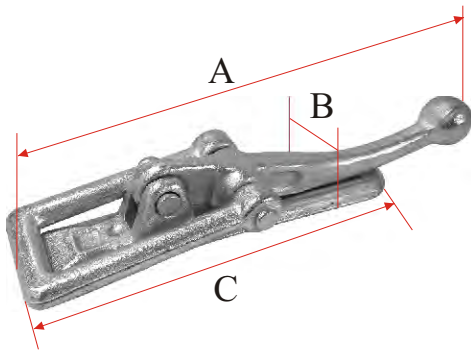

## CIERRE TRASERO

REF.	A (mm)	B (mm)	C (mm)
C-2 ZINC	257	31	208
C-3 ZINC	193	26	146
C-4 ZINC	149	22	114

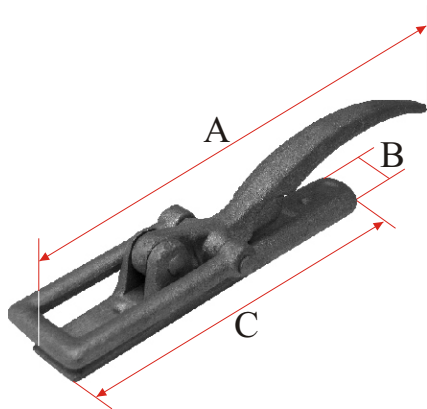

## CIERRE TRASERO

REF.	A (mm)	B (mm)	C (mm)
C-12	264	31	199
C-13	202	26	156
C-14	163	22	114

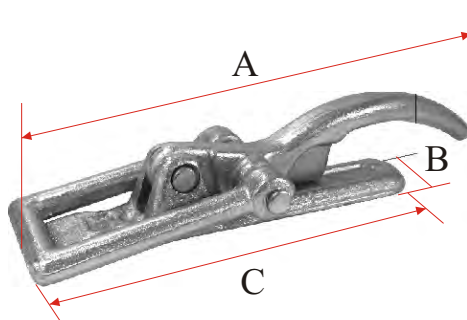

## CIERRE TRASERO

REF.	A (mm)	B (mm)	C (mm)
C-12 ZINC	264	31	199
C-13 ZINC	202	26	156
C-14 ZINC	163	22	114

**CIERRE TRASERO**

REF.	A (mm)	B (mm)	C (mm)
C-5	135	21	114

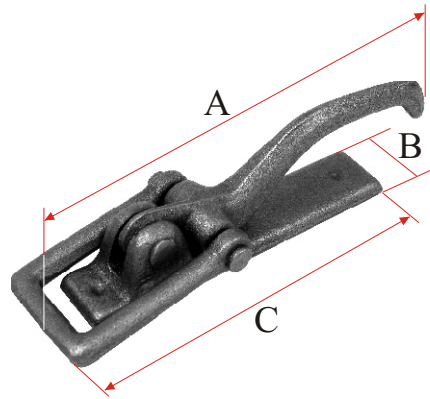

**CIERRE TRASERO**

REF.	A (mm)	B (mm)	C (mm)
C-5 ZINC	135	21	114

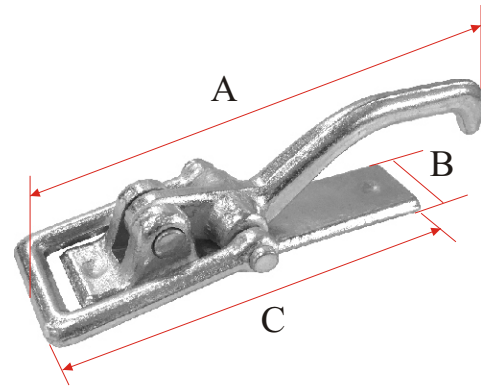

**CIERRE TRASERO**

REF.	A (mm)	B (mm)
C-7 ZINC	312	34

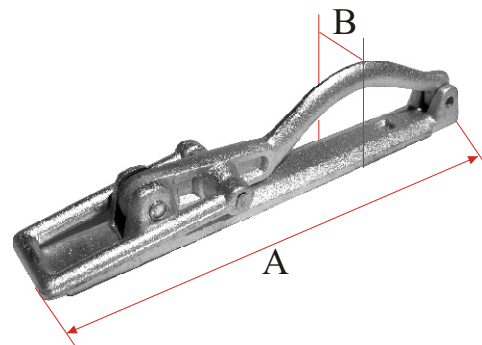

**CIERRE TRASERO**

REF.	A (mm)	B (mm)	C (mm)
C-8	278	31	189
C-9	202	26	150

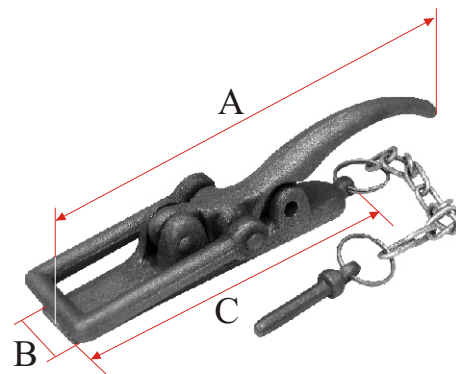

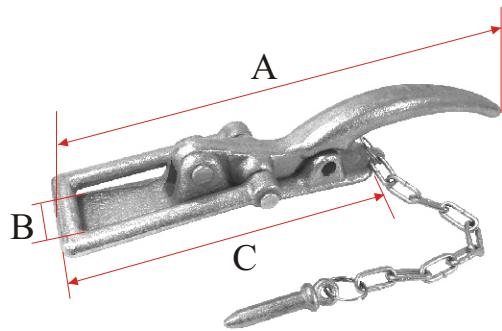

**CIERRE TRASERO**

REF.	A (mm)	B (mm)	C (mm)
C-8 ZINC	278	31	189
C-9 ZINC	202	26	150

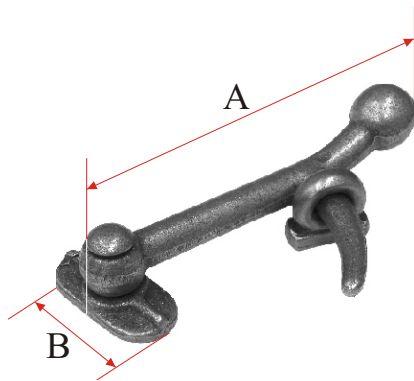

**CIERRE TRASERO**

REF.	A (mm)	B (mm)
CP-1	200	65
CP-1 lz.	200	65
CP-2	173	60
CP-2 lz.	173	60
CP-3	145	50
CP-3 lz.	145	50

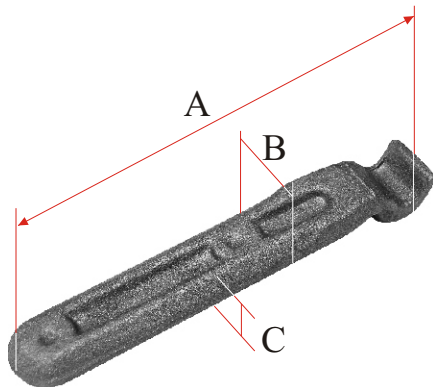

**UÑA DE FORJA FIJA**

REF.	A (mm)	B (mm)	C (mm)
U-2	175	30	9
U-3	130	23	6
U-4	107	18	7

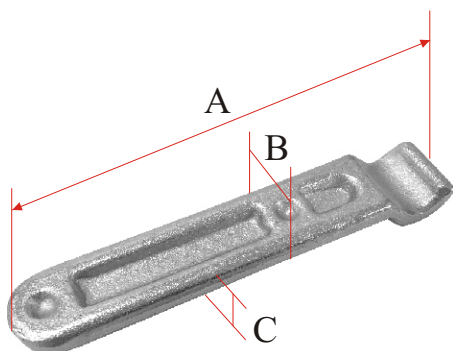

**UÑA DE FORJA FIJA**

REF.	A (mm)	B (mm)	C (mm)
U-2 ZINC	175	30	9
U-3 ZINC	130	23	6
U-4 ZINC	107	18	7

**UÑA DE FORJA ARTICULADA**

REF.	A (mm)	B (mm)	C (mm)
U-6	60	47	91

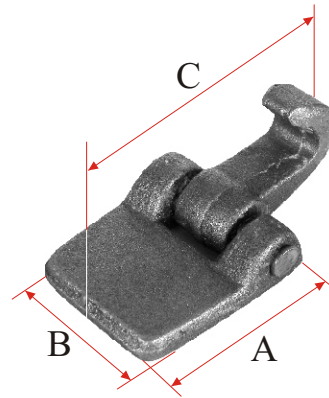

**UÑA DE FORJA ARTICULADA**

REF.	A (mm)	B (mm)	C (mm)
U-6 ZINC	60	47	91

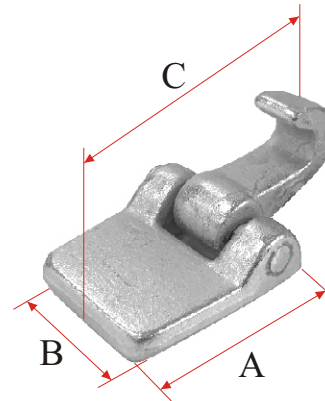

**UÑA DE FORJA ARTICULADA**

REF.	A (mm)	B (mm)	C (mm)
U-7	38	50	71

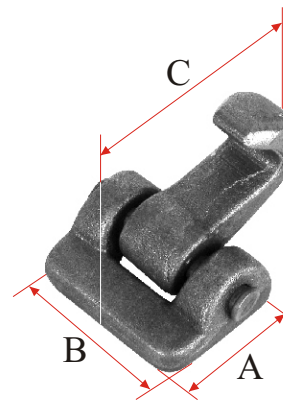

**UÑA DE FORJA ARTICULADA**

REF.	A (mm)	B (mm)	C (mm)
U-7 ZINC	38	50	71

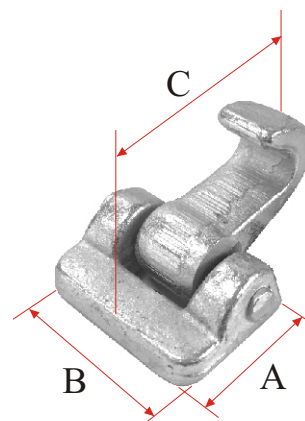



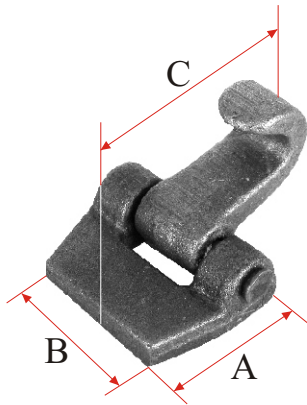

**UÑA DE FORJA ARTICULADA**

REF.	A (mm)	B (mm)	C (mm)
U-8	46	47	82

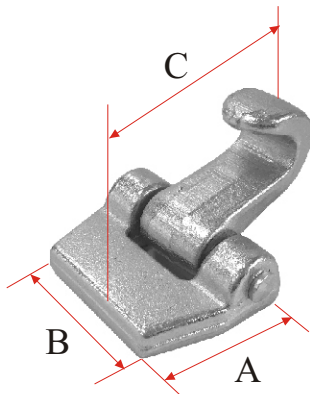

**UÑA DE FORJA ARTICULADA**

REF.	A (mm)	B (mm)	C (mm)
U-8 ZINC	46	47	82

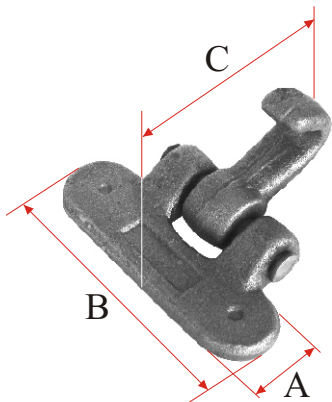

**UÑA DE FORJA ARTICULADA**

REF.	A (mm)	B (mm)	C (mm)
U-9	24	78	74

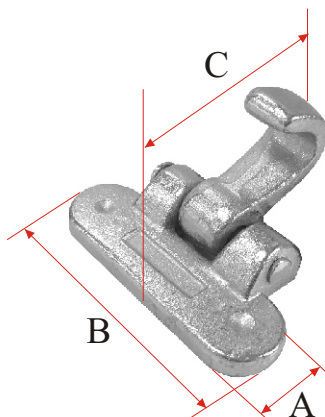

**UÑA DE FORJA ARTICULADA**

REF.	A (mm)	B (mm)	C (mm)
U-9 ZINC	24	78	74

**CIERRE REGULABLE**

REF.	A (mm)	B (mm)	C (mm)
CH-30	232	83	40

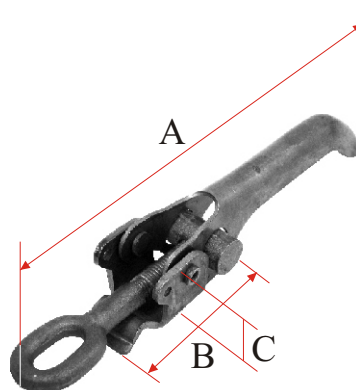

**CIERRE REGULABLE**

REF.	A (mm)	B (mm)	C (mm)
CH-30 ZINC	232	83	40

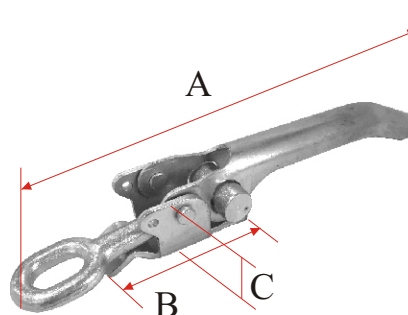

**CIERRE REGULABLE**

REF.	A (mm)	B (mm)	C (mm)
CH-31	182	40	25

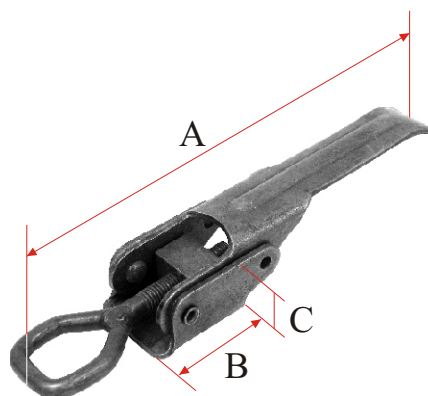

**CIERRE REGULABLE**

REF.	A (mm)	B (mm)	C (mm)
C-15 ZINC	260	106	35

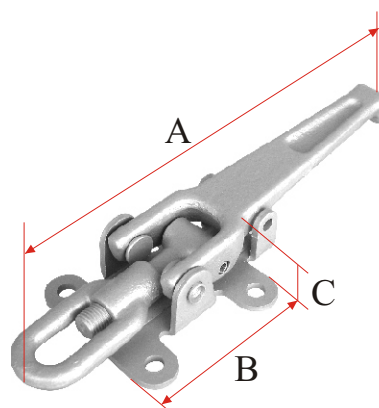

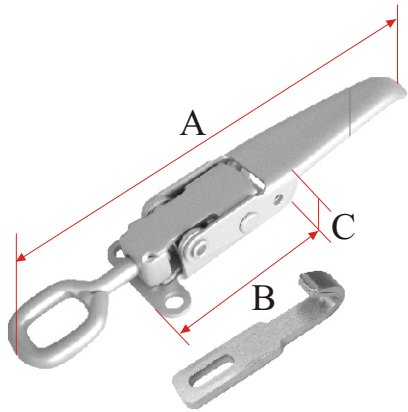

## CIERRE REGULABLE

REF.	A (mm)	B (mm)	C (mm)
CH-33 ZINC	240	82	30
CH-33 INOX	240	82	30

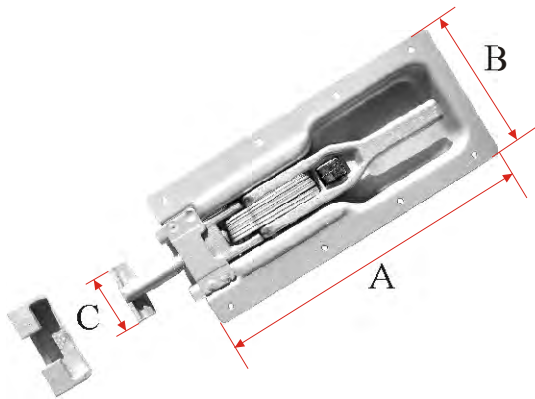

## CIERRE REGULABLE

REF.	A (mm)	B (mm)	C (mm)
C-16 ZINC	270	120	53

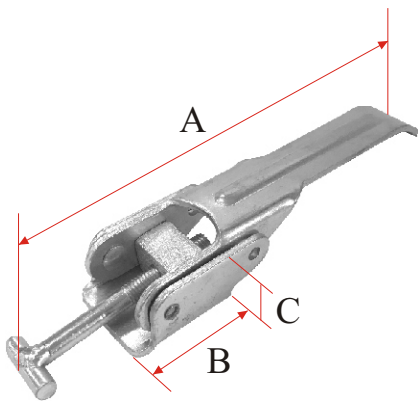

## CIERRE REGULABLE

REF.	A (mm)	B (mm)	C (mm)
CH-32 ZINC	190	40	24

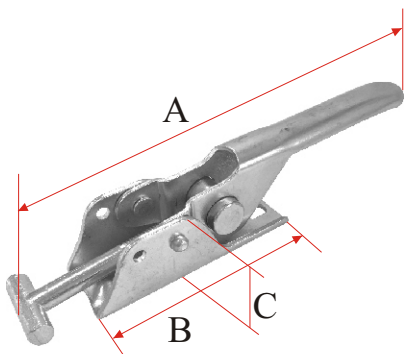

## CIERRE REGULABLE

REF.	A (mm)	B (mm)	C (mm)
CH-35 ZINC	235	106	36

## CIERRE REGULABLE

REF.	A (mm)	B (mm)	C (mm)
C-17 ZINC	275	120	32

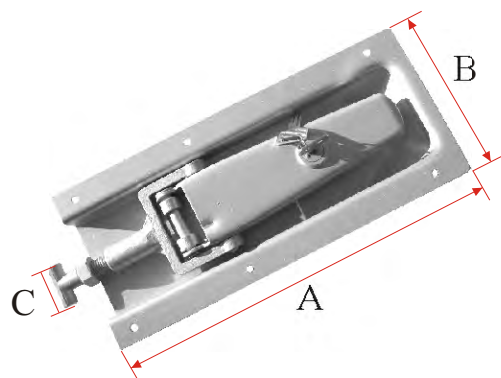

## UÑA PARA C. REGULABLE

REF.	A (mm)	B (mm)	C (mm)
U-30	37	22	9

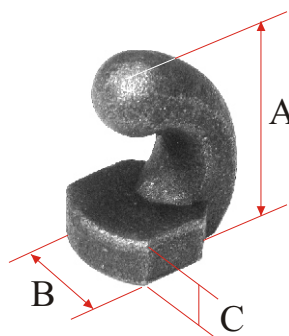

## UÑA PARA C. REGULABLE

REF.	A (mm)	B (mm)	C (mm)
UH-31	32	19	30

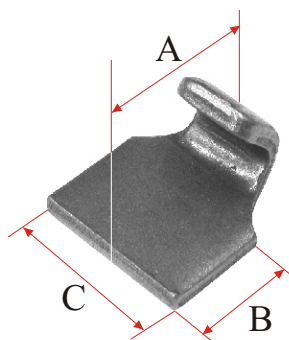

## UÑA PARA C. REGULABLE

REF.	A (mm)	B (mm)	C (mm)
UH-32 ZINC	32	30	4

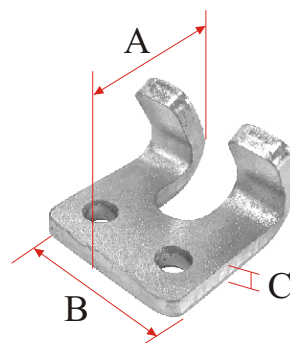

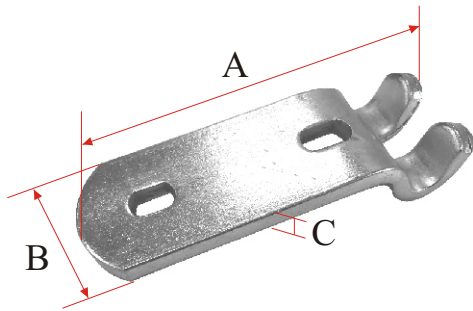

## UÑA PARA C. REGULABLE

REF.	A (mm)	B (mm)	C (mm)
UH-35 ZINC	115	40	6

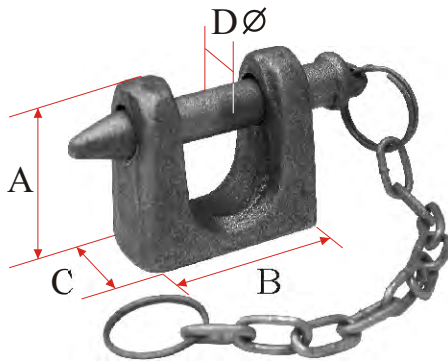

## CIERRE DE BULÓN

REF.	A (mm)	B (mm)	C (mm)	D (mm)
C-11	51	56	25	12

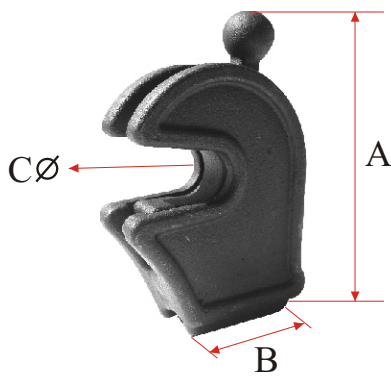

## CIERRE DE BULÓN

REF.	A (mm)	B (mm)	C (mm)
CB-10	136	67	23
CB-30	135	75	33

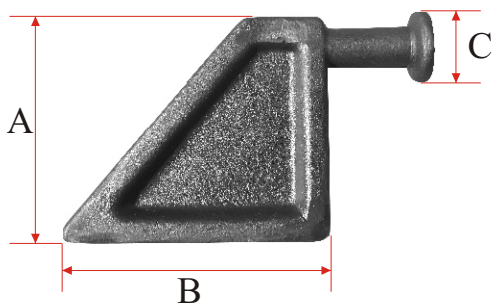

## CIERRE DE BULÓN

REF.	A (mm)	B (mm)	C (mm)
UB-10	107	129	35
UB-30	115	129	40

**CIERRE DE CHAPA**

REF.	A (mm)	B (mm)	C (mm)
CH-10 ZINC	144	48	68

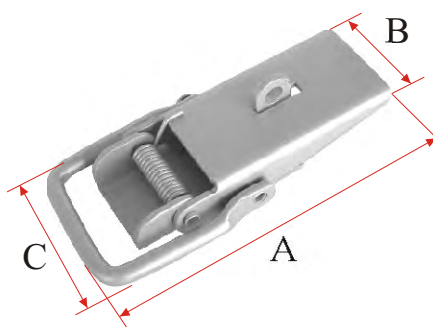

**CIERRE DE CHAPA**

REF.	A (mm)	B (mm)	C (mm)
CH-10.2 ZINC	140	48	68

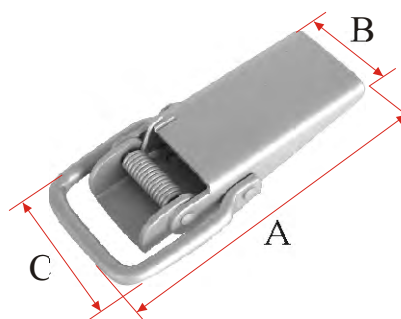

**CIERRE DE CHAPA**

REF.	A (mm)	B (mm)	C (mm)
CH-10.3 ZINC	107	30	47

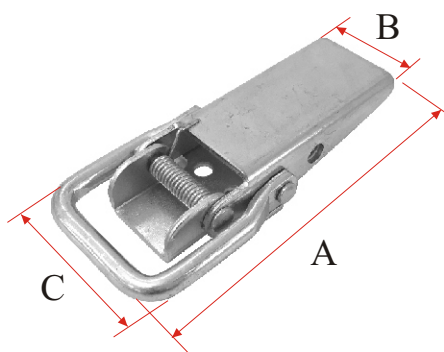

**CIERRE DE CHAPA**

REF.	A (mm)	B (mm)	C (mm)
CH-13.2 ZINC	129	38	55

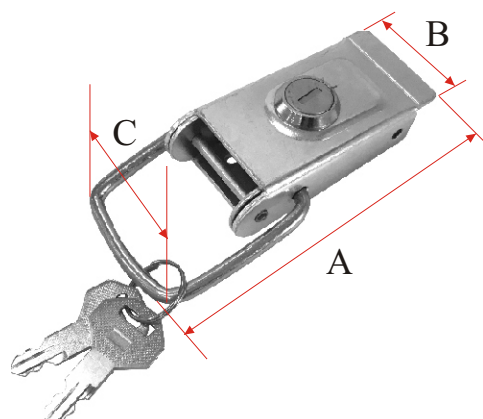

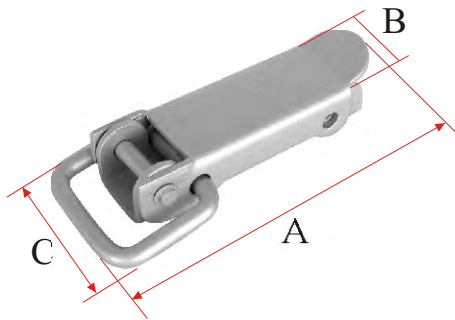

**CIERRE DE CHAPA**

REF.	A (mm)	B (mm)	C (mm)
CH-14 ZINC	89	24	39

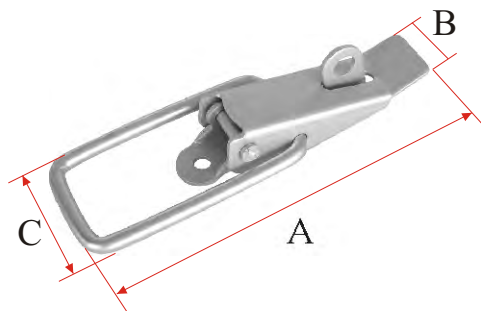

**CIERRE DE CHAPA**

REF.	A (mm)	B (mm)	C (mm)
CH-15 ZINC	120	20	40

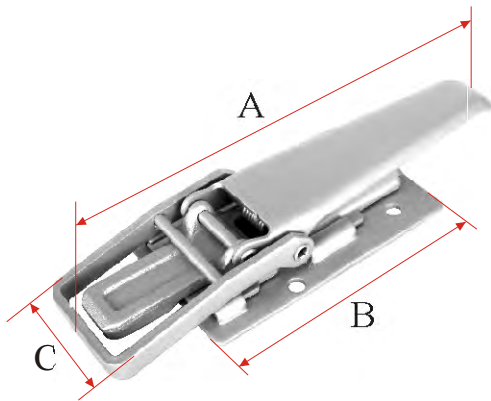

**CIERRE DE CHAPA**

REF.	A (mm)	B (mm)	C (mm)
CH-20 ZINC	260	143	63

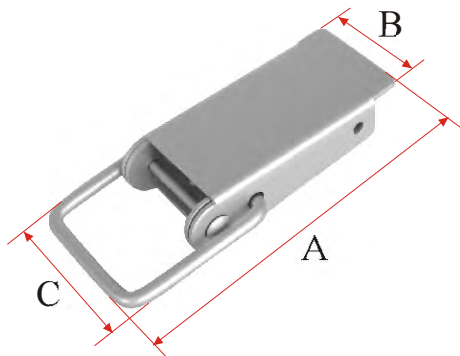

**CIERRE DE CHAPA**

REF.	A (mm)	B (mm)	C (mm)
CH-21 ZINC	115	40	53

**CIERRE DE CHAPA**

REF.	A (mm)	B (mm)	C (mm)
CH-3	213	130	27
CH-4	160	104	24

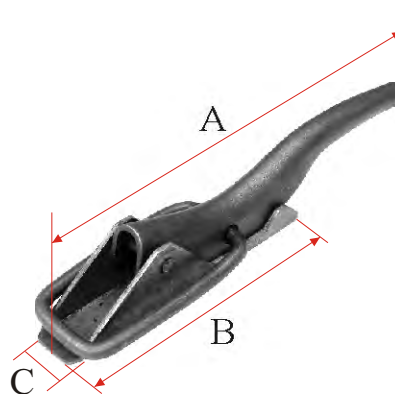

**CIERRE DE CHAPA**

REF.	A (mm)	B (mm)	C (mm)
CH-8	265	165	30

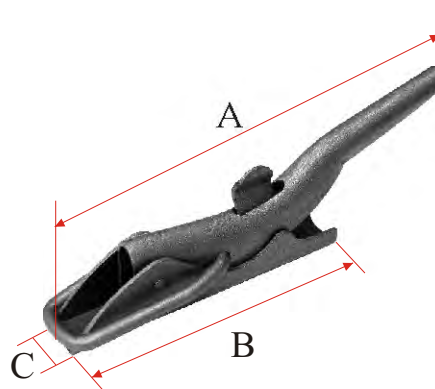

**UÑA DE CHAPA**

REF.	A (mm)	B (mm)	C (mm)
UH 3/8"	140	30	7
UH-4	102	19	5

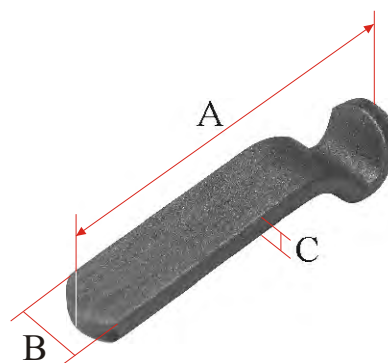

**UÑA DE CHAPA**

REF.	A (mm)	B (mm)	C (mm)
UH-20 ZINC	45	16	22

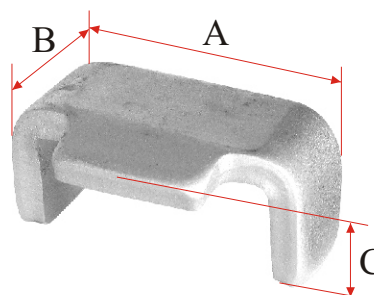



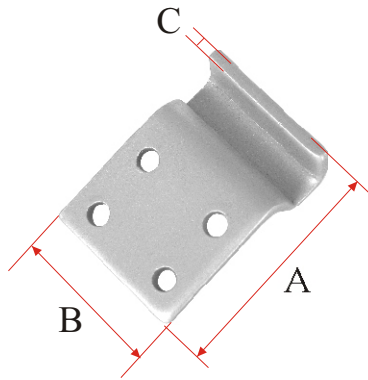

UÑA DE CHAPA			
REF.	A (mm)	B (mm)	C (mm)
UH-10 ZINC	57	40	4

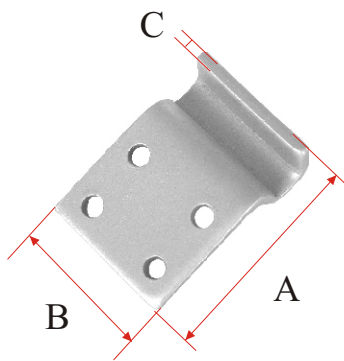

UÑA DE CHAPA			
REF.	A (mm)	B (mm)	C (mm)
UH-10.3 ZINC	48.5	40	4

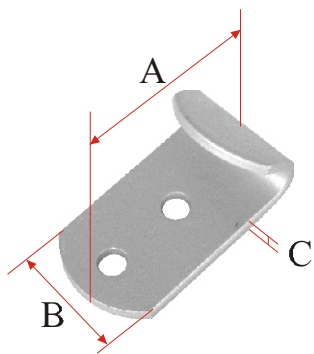

UÑA DE CHAPA			
REF.	A (mm)	B (mm)	C (mm)
UH-11 ZINC	68	40	4

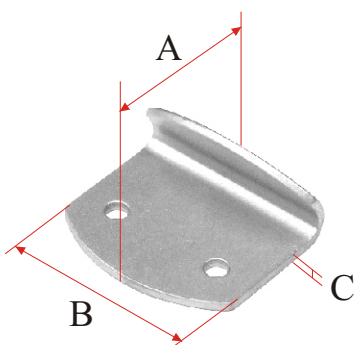

UÑA DE CHAPA			
REF.	A (mm)	B (mm)	C (mm)
UH-12 ZINC	33	40	2

**UÑA DE CHAPA**

REF.	A (mm)	B (mm)	C (mm)
UH-13 ZINC	75	40	2

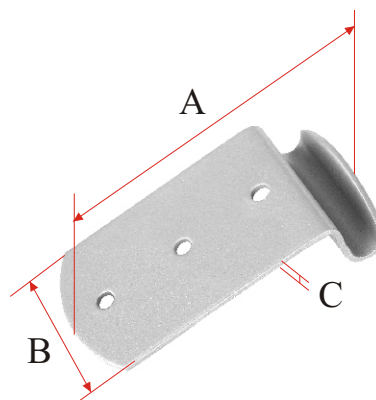

**UÑA DE CHAPA**

REF.	A (mm)	B (mm)	C (mm)
UH-14 ZINC	86	25	3

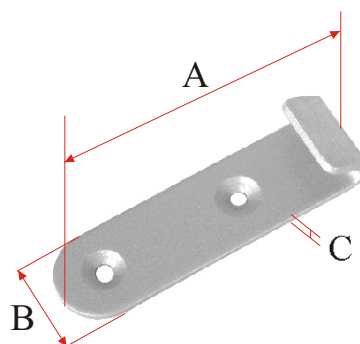

**UÑA DE CHAPA**

REF.	A (mm)	B (mm)	C (mm)
UH-15 ZINC	83	25	3

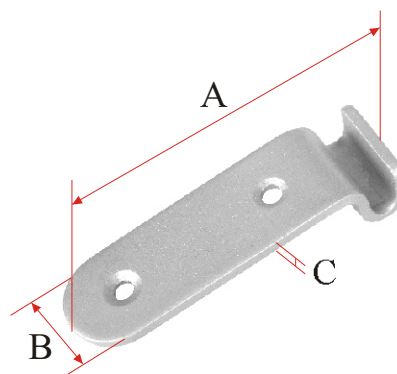

**UÑA DE CHAPA**

REF.	A (mm)	B (mm)	C (mm)
UH-20.2 ZINC	100	30	24

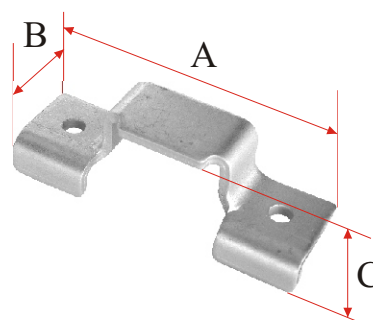

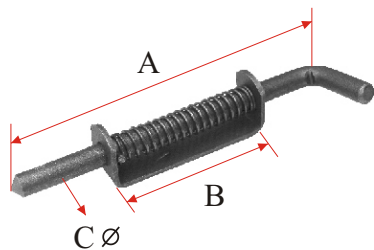

## CERROJO CON MUELLE

REF.	A (mm)	B (mm)	C (mm)
CG-2	218	110	14

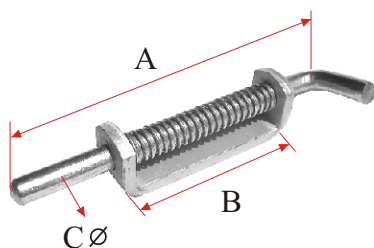

## CERROJO CON MUELLE

REF.	A (mm)	B (mm)	C (mm)
CG-2 ALU	210	115	14

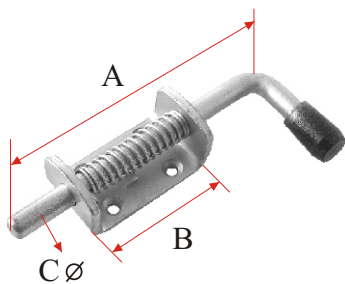

## CERROJO CON MUELLE

REF.	A (mm)	B (mm)	C (mm)
CG-4 ZINC	162	75	12

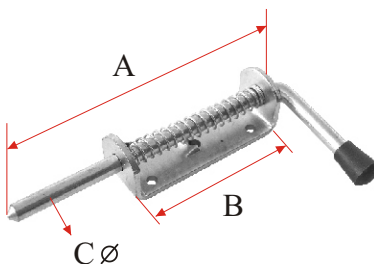

## CERROJO CON MUELLE

REF.	A (mm)	B (mm)	C (mm)
CG-6 ZINC	230	120	12
CG-8 ZINC	260	133	16

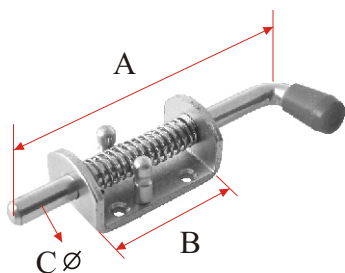

## CERROJO CON MUELLE

REF.	A (mm)	B (mm)	C (mm)
CG-7 ZINC	165	73	12

**CERROJO CON MUELLE**

REF.	A (mm)	B (mm)	C (mm)	D (mm)
CG-1	192	21	10	35
CG-14	222	26	14	53

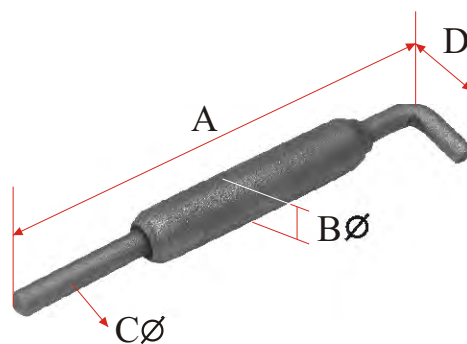

**CERROJO CON MUELLE**

REF.	A (mm)	B (mm)	C (mm)	D (mm)
CG-14 ZINC	222	26	14	53

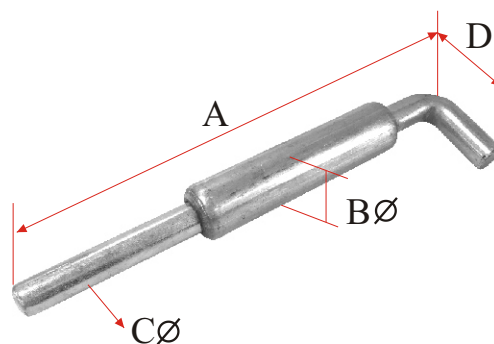

**CERROJO CON MUELLE**

REF.	A (mm)	B (mm)	C (mm)	D (mm)
CG-1 L	165	19	10	90
CG-14 L	190	25	14	103

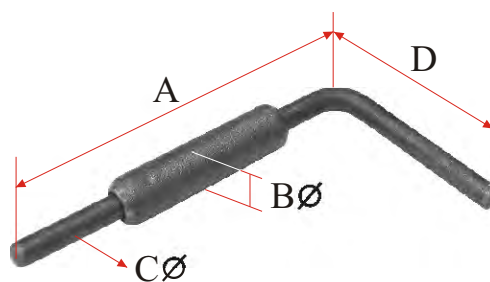

**CERROJO CON MUELLE**

REF.	A (mm)	B (mm)	C (mm)
CG-3	185	25	14

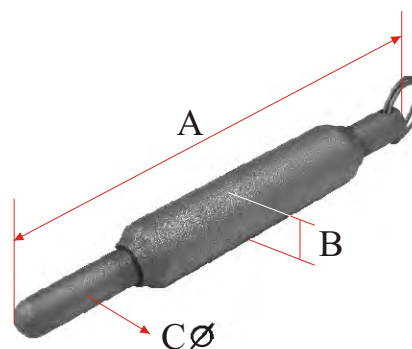

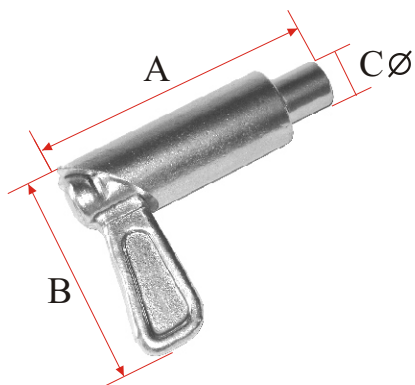

**CERROJO CON MUELLE**

REF.	A (mm)	B (mm)	C (mm)
CG-10 ZINC	71	49	12
CG-10.2 ZINC	71	49	14

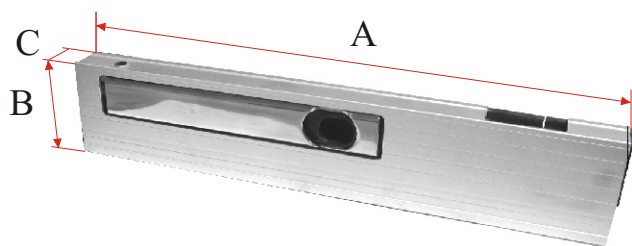

**CIERRE DE ALUMINIO**

REF.	A (mm)	B (mm)	C (mm)
CA-415 I ALU	415	78	25
CA-415 D ALU	415	78	25
CA-615 I ALU	615	78	25
CA-615 D ALU	615	78	25
CA-815 I ALU	815	78	25
CA-815 D ALU	815	78	25
CA-1015 I ALU	1015	78	25
CA-1015 D ALU	1015	78	25

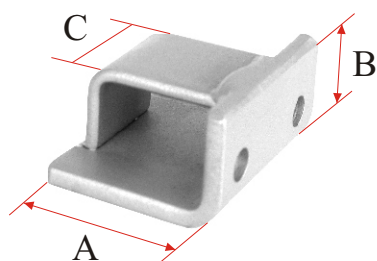

**UÑA DE CIERRE DE ALUMINIO**

REF.	A (mm)	B (mm)	C (mm)
UCA-1 ZINC	40	27	25

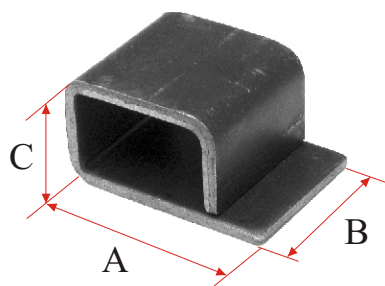

**UÑA DE CIERRE DE ALUMINIO**

REF.	A (mm)	B (mm)	C (mm)
UCA-2	41	30	22

**CIERRE DE CAJÓN**

REF.	A (mm)	B (mm)	C (mm)
CC-1 ZINC	124	121	25
CC-1 INOX	124	121	25

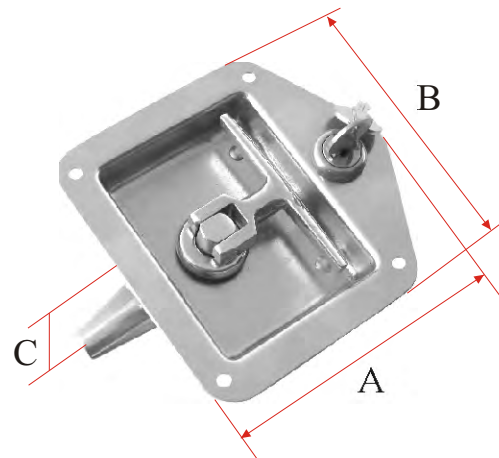

**CIERRE DE CAJÓN**

REF.	A (mm)	B (mm)
CC-2 ZINC	140	108
CC-2 INOX	140	108

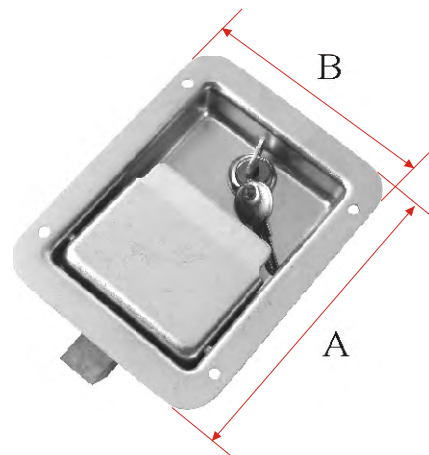

**CIERRE DE CAJÓN**

REF.	A (mm)	B (mm)
CC-3 ZINC	120	92
CC-3 INOX	120	92

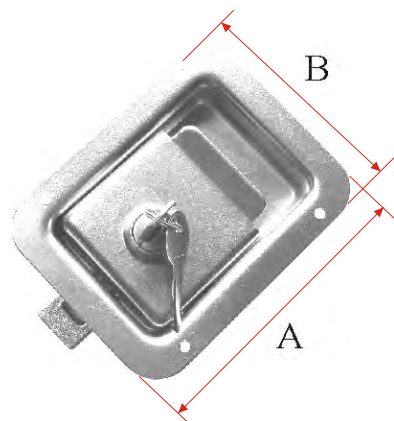

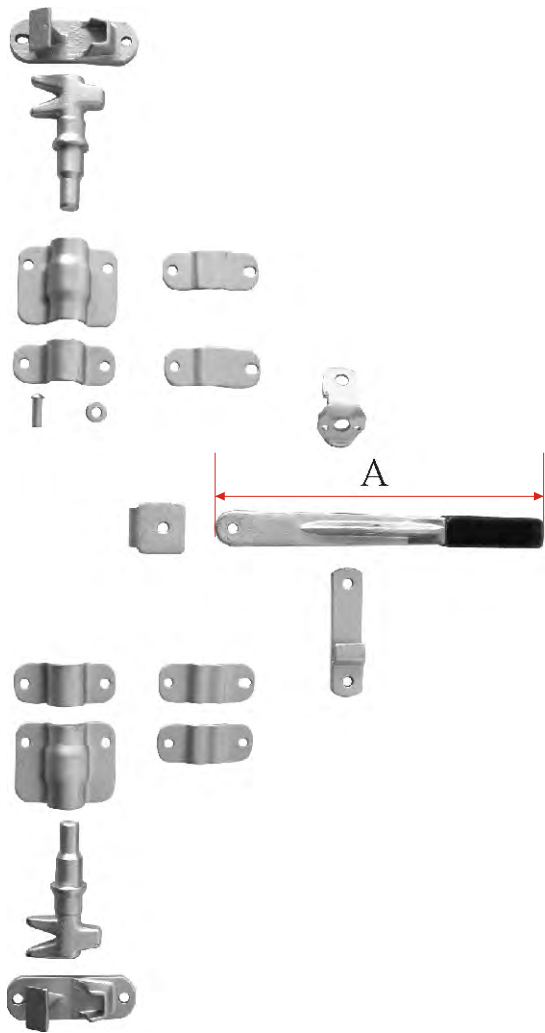

PARA TUBO DE 27mm

**CIERRE DE FALLEBA**

REF.	A (mm)
CF-1 ZINC	343

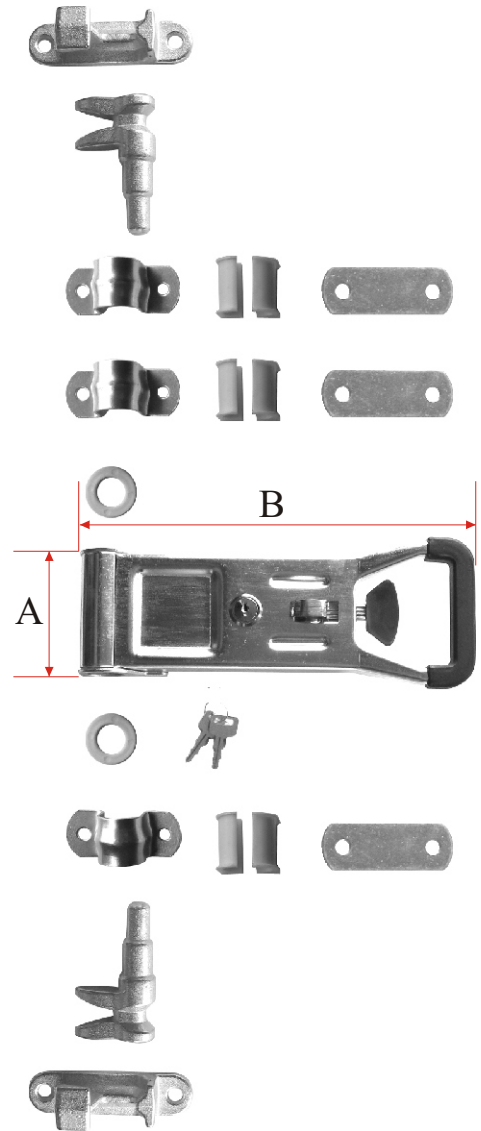

PARA TUBO DE 20mm

**CIERRE DE FALLEBA**

REF.	A (mm)	B (mm)
CF-20 ZINC	90	260

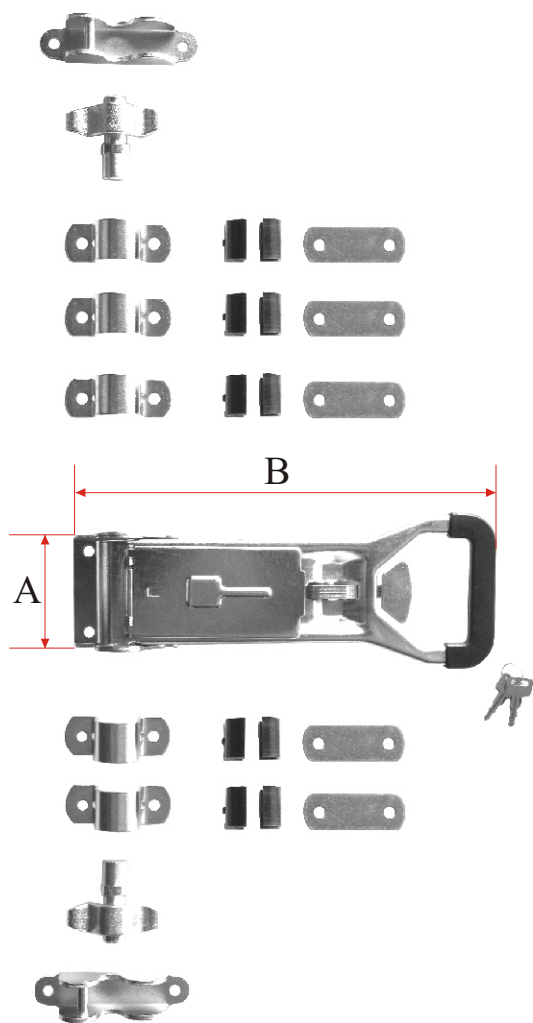

PARA TUBO DE 25mm

### CIERRE DE FALLEBA

REF.	A (mm)	B (mm)
CF-25 ZINC	85	320

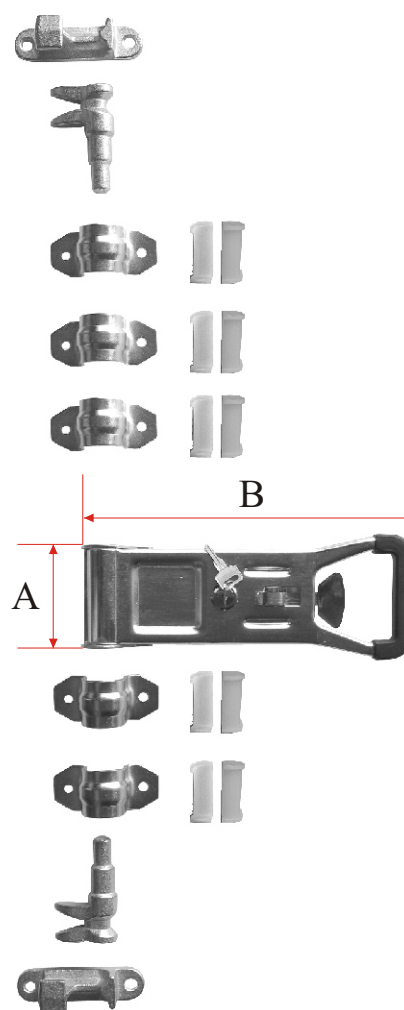

PARA TUBO DE 27mm

### CIERRE DE FALLEBA

REF.	A (mm)	B (mm)
CF-27 ZINC	85	280



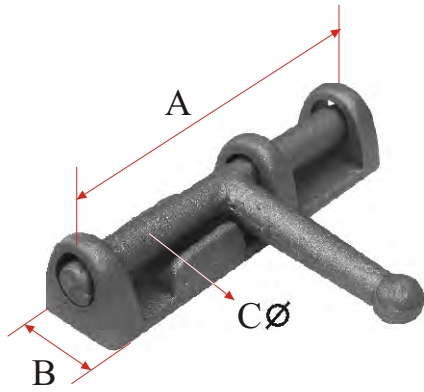

CERROJO			
REF.	A (mm)	B (mm)	C (mm)
CR-1	180	40	19
CR-2	154	37	16

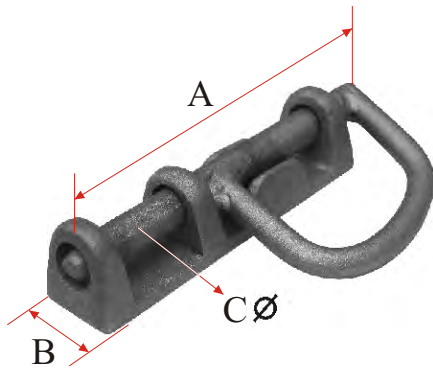

CERROJO			
REF.	A (mm)	B (mm)	C (mm)
CR-5	200	40	18
CR-6	170	35	17

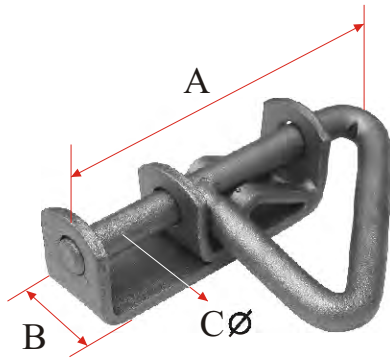

CERROJO			
REF.	A (mm)	B (mm)	C (mm)
CRH-6	177	40	16

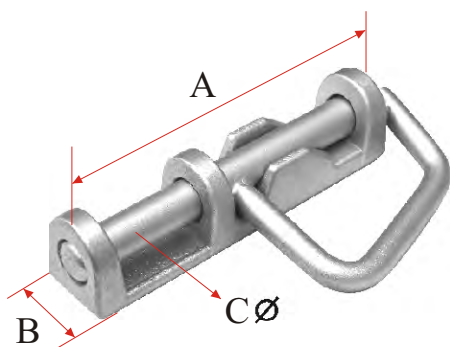

CERROJO			
REF.	A (mm)	B (mm)	C (mm)
CR-6 ALU	155	34	17

**ACC. PARA CONTENEDORES Y BASCULANTES**

REF.	A (mm)	B (mm)	C (mm)	D (mm)
HB-1	180	105	13	35

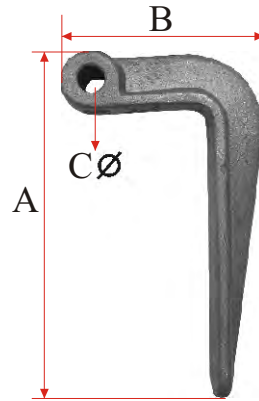

**ACC. PARA CONTENEDORES Y BASCULANTES**

REF.	A (mm)	B (mm)	C (mm)	D (mm)
HB-2	215	140	13	35

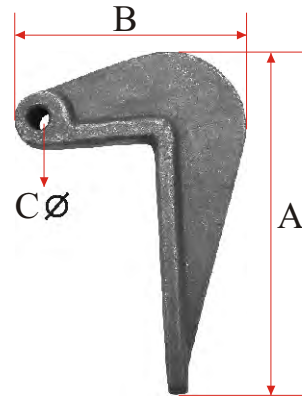

**ACC. PARA CONTENEDORES Y BASCULANTES**

REF.	A (mm)	B (mm)	C (mm)	D (mm)
SHB-1	71	28	56	13

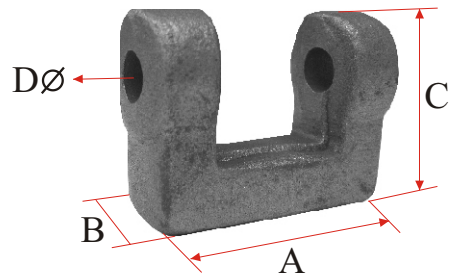

**ACC. PARA CONTENEDORES Y BASCULANTES**

REF.	A (mm)	B (mm)	C (mm)	D (mm)
CB-1	270	75	118	51

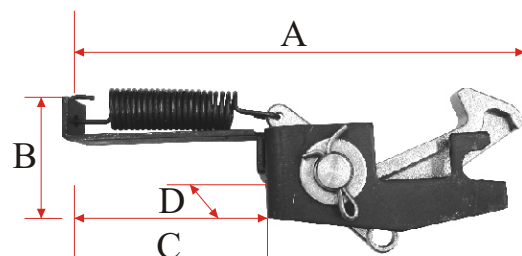

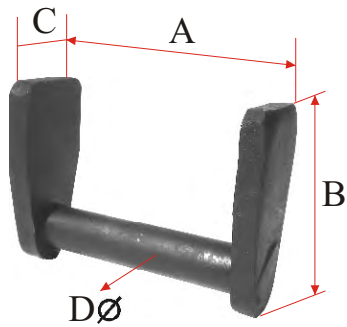

**ACC. PARA CONTENEDORES Y BASCULANTES**

REF.	A (mm)	B (mm)	C (mm)	D (mm)
UB-1	78	58	30	14

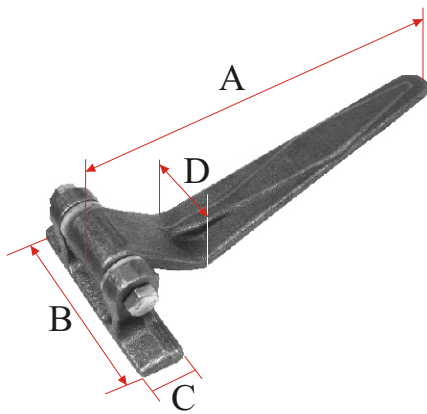

**ACC. PARA CONTENEDORES Y BASCULANTES**

REF.	A (mm)	B (mm)	C (mm)	D (mm)
B-1 c/c	275	120	32	45

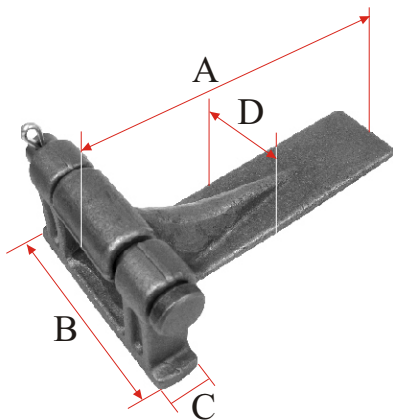

**ACC. PARA CONTENEDORES Y BASCULANTES**

REF.	A (mm)	B (mm)	C (mm)	D (mm)
B-4	225	143	27	60

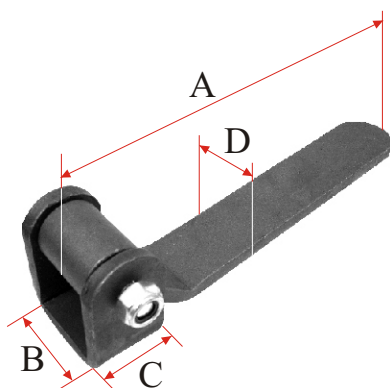

**ACC. PARA CONTENEDORES Y BASCULANTES**

REF.	A (mm)	B (mm)	C (mm)	D (mm)
B-10	307	74	50	50
B-11	222	69	35	50

**ACC. PARA CONTENEDORES Y BASCULANTES**

REF.	A (mm)	B (mm)	C (mm)	D (mm)
BL-1	70	40	90	12

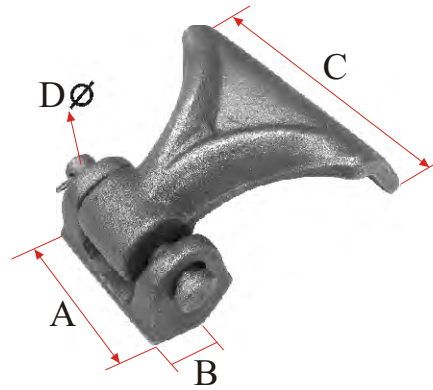

**ACC. PARA CONTENEDORES Y BASCULANTES**

REF.	A (mm)	B (mm)	C (mm)
UV-2	228	160	68

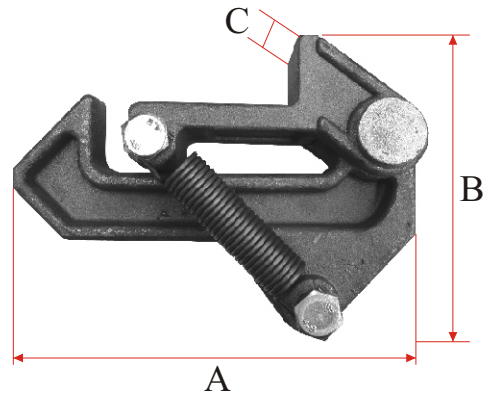

**ACC. PARA CONTENEDORES Y BASCULANTES**

REF.	A (mm)	B (mm)	C (mm)	D (mm)
UV-2 S/S	228	130	38	25

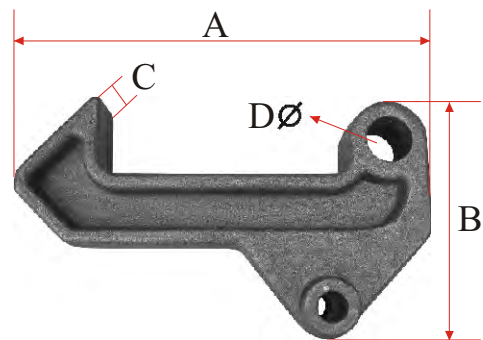

**ACC. PARA CONTENEDORES Y BASCULANTES**

REF.	A (mm)	B (mm)	C (mm)	D (mm)
B-15 I	79	64	53	32
B-15 D	79	64	53	32

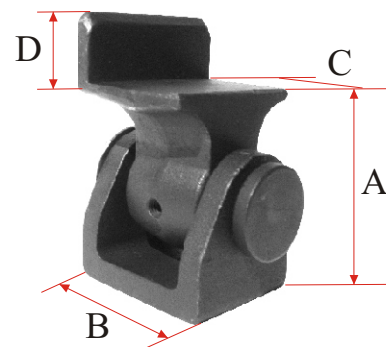

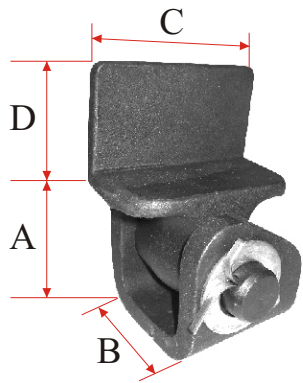

**ACC. PARA CONTENEDORES Y BASCULANTES**

REF.	A (mm)	B (mm)	C (mm)	D (mm)
B-16 I	100	92	109	66
B-16 D	100	92	109	66

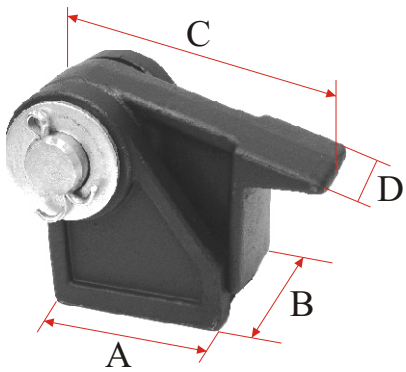

**ACC. PARA CONTENEDORES Y BASCULANTES**

REF.	A (mm)	B (mm)	C (mm)	D (mm)
B-20	90	68	154	50

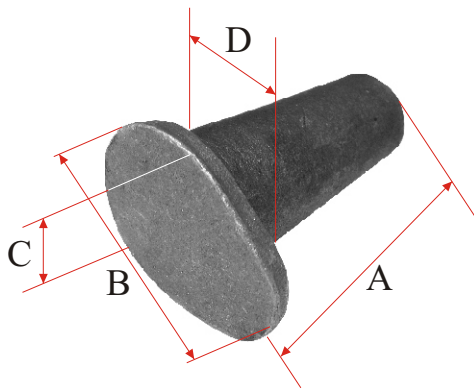

**ACC. PARA CONTENEDORES Y BASCULANTES**

REF.	A (mm)	B (mm)	C (mm)	D (mm)
BC-105	117	83	68	52
BC-115	127	83	68	52

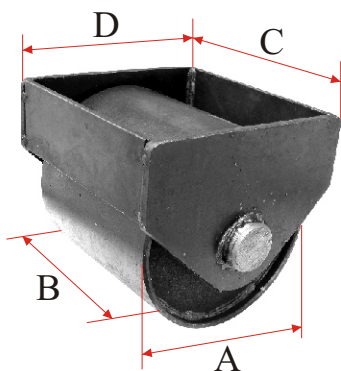

**ACC. PARA CONTENEDORES Y BASCULANTES**

REF.	A (mm)	B (mm)	C (mm)	D (mm)
D 160	160	160	192	178
D 200	200	180	235	230

**MACHO**

REF.	A (mm)	B (mm)	C (mm)	D (mm)
M-1	127	71	34.5	19

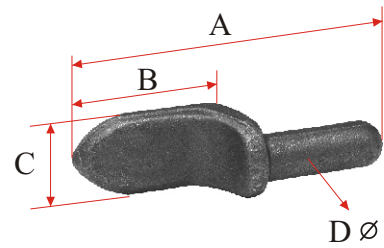

**MACHO**

REF.	A (mm)	B (mm)	C (mm)	D (mm)
M-2	200	135	35	18
M-3	170	118	33	17
M-4	123	70	31	17

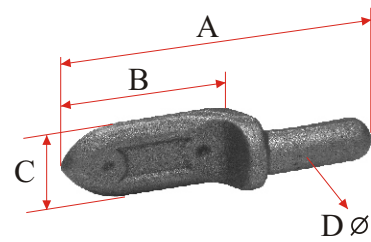

**MACHO**

REF.	A (mm)	B (mm)	C (mm)	D (mm)
M-5	127	75	34	17
M-6	114	67	31	15

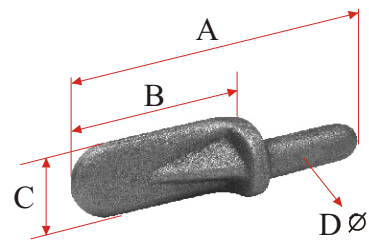

**MACHO**

REF.	A (mm)	B (mm)	C (mm)	D (mm)
M-8	110	69	30	15
M-8 G	115	71	31	15

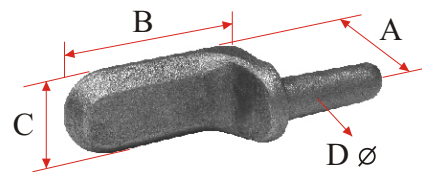

**MACHO**

REF.	A (mm)	B (mm)	C (mm)	D (mm)
M-40	128	84	30	14
M-41 ZINC	142	93	37	15

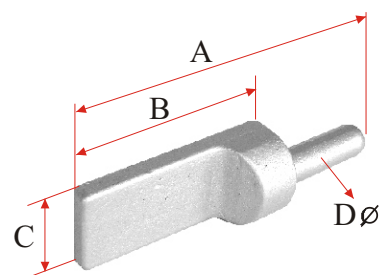

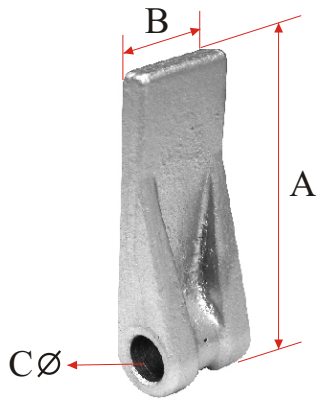

HEMBRA			
REF.	A (mm)	B (mm)	C (mm)
H-40	103	35	14.5
H-41 ZINC	115	39	16.5

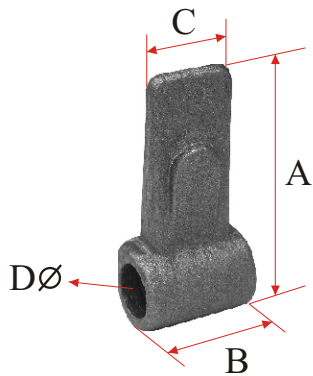

HEMBRA				
REF.	A (mm)	B (mm)	C (mm)	D (mm)
H-1	103	45	32	20
H-2	90	43	30	18

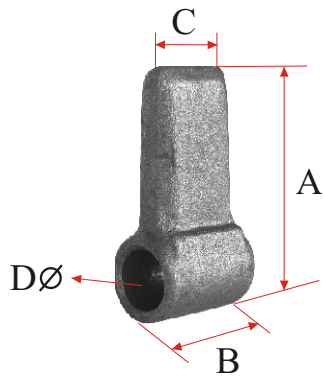

HEMBRA				
REF.	A (mm)	B (mm)	C (mm)	D (mm)
H-3	77	38	31	18

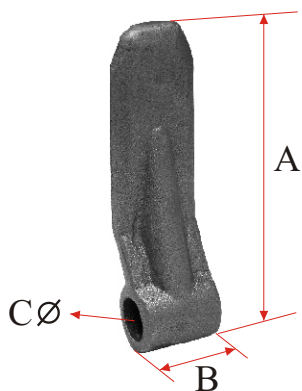

HEMBRA			
REF.	A (mm)	B (mm)	C (mm)
H-5	156	40	20
H-10	131	36	18

**HEMBRA**

REF.	A (mm)	B (mm)	C (mm)
H-15	140	36	18

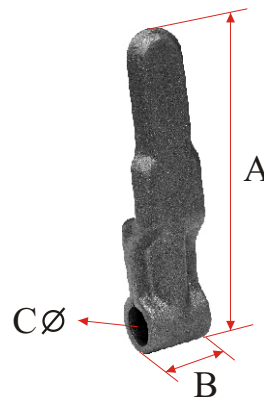

**HEMBRA**

REF.	A (mm)	B (mm)	C (mm)
H-16 ZINC	225	72	18

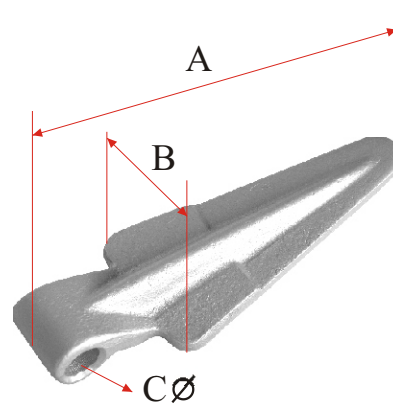

**HEMBRA**

REF.	A (mm)	B (mm)	C (mm)
H-6	122	33	16

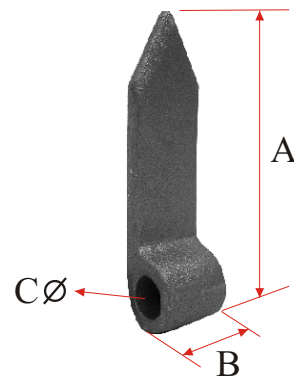

**HEMBRA**

REF.	A (mm)	B (mm)	C (mm)
H-7	91	33	16

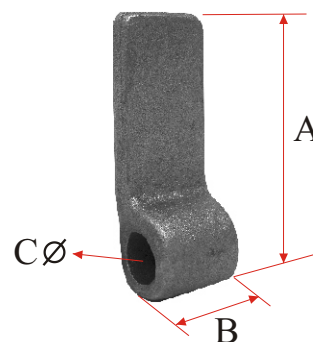



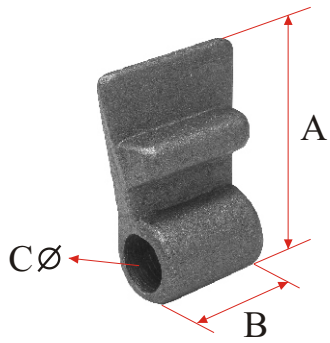

HEMBRA			
REF.	A (mm)	B (mm)	C (mm)
H-13	74	40	18

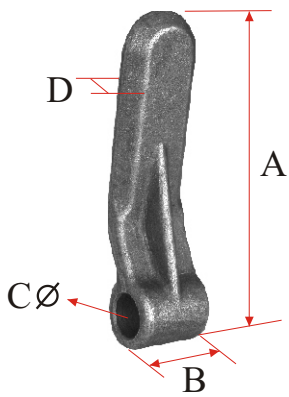

HEMBRA				
REF.	A (mm)	B (mm)	C (mm)	D (mm)
H-5 G	155	40	20	12

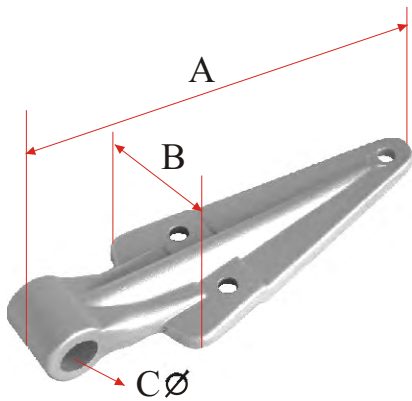

HEMBRA			
REF.	A (mm)	B (mm)	C (mm)
H-16 ALU	220	72	18

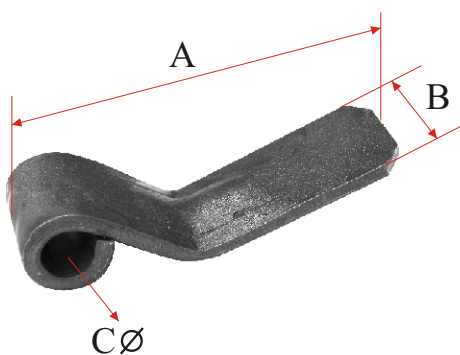

HEMBRA			
REF.	A (mm)	B (mm)	C (mm)
HH-10	130	39	18

**HEMBRA**

REF.	A (mm)	B (mm)	C (mm)
H-18	170	52	28

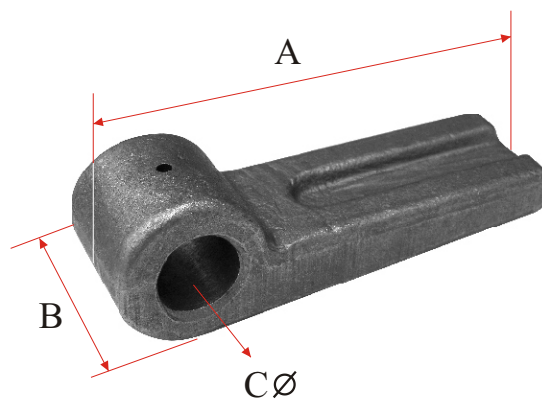

**HEMBRA**

REF.	A (mm)	B (mm)	C (mm)
H-20	125	58.5	36

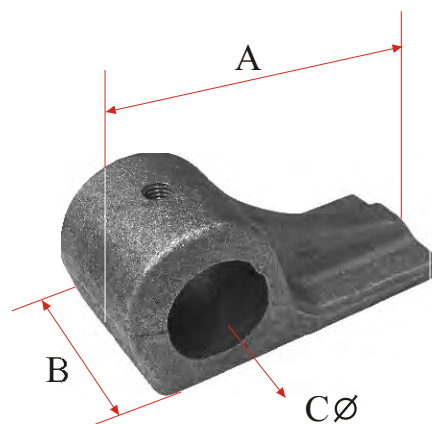

**HEMBRA**

REF.	A (mm)	B (mm)	C (mm)
H-28	180	49	22

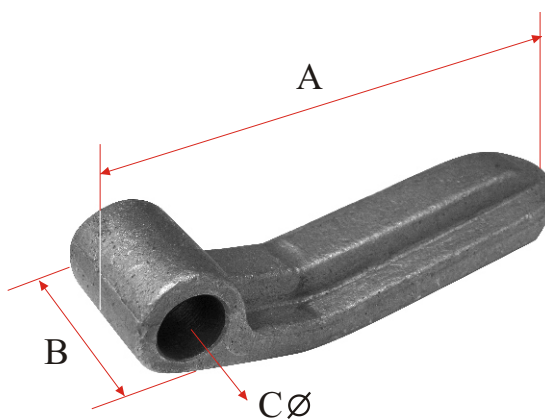

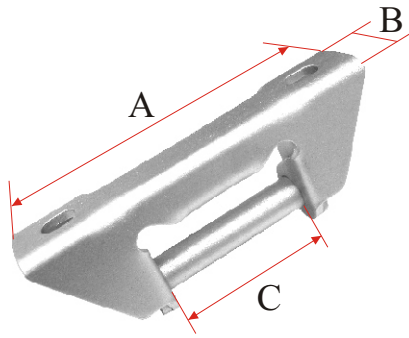

## BISAGRA COMPLETA

REF.	A (mm)	B (mm)	C (mm)
TIR-8 S/S ZINC	124	27	55

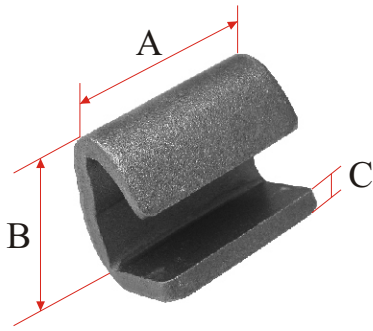

## BISAGRA COMPLETA

REF.	A (mm)	B (mm)	C (mm)
S-1	50	43	6

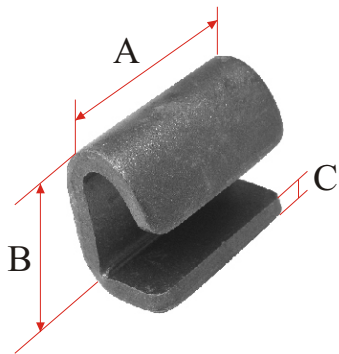

## BISAGRA COMPLETA

REF.	A (mm)	B (mm)	C (mm)
S-2	50	43	6

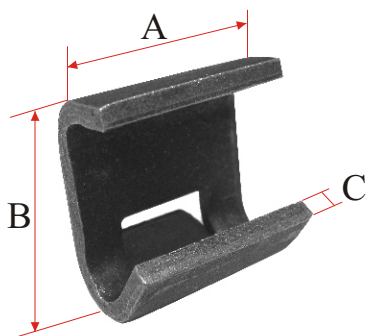

## BISAGRA COMPLETA

REF.	A (mm)	B (mm)	C (mm)
S-3	50	40	6

**BISAGRA COMPLETA**

REF.	A (mm)	B (mm)	C (mm)	D (mm)
PLT-1 ZINC	40	18	6	8

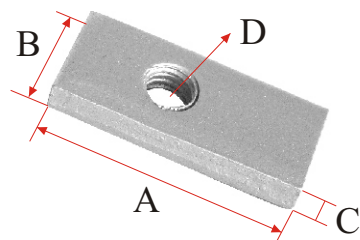
**BISAGRA COMPLETA**

REF.	A (mm)	B (mm)	C (mm)	D (mm)
PLT-2 ZINC	95	18	6	8

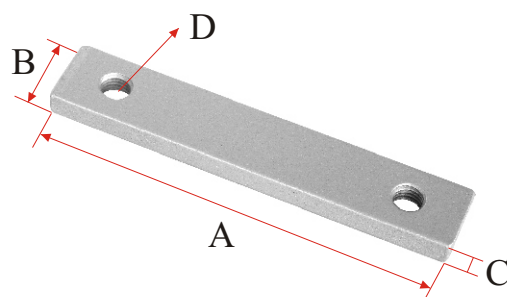

**BISAGRA COMPLETA**

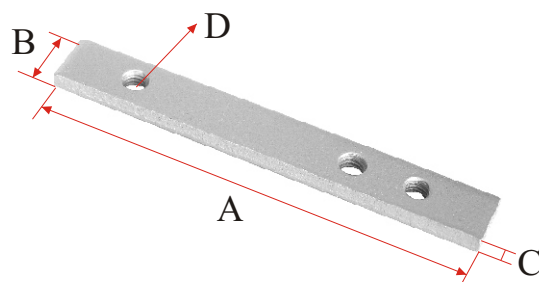
REF.	A (mm)	B (mm)	C (mm)	D (mm)
PLT-3 ZINC	135	18	6	8

**BISAGRA COMPLETA**

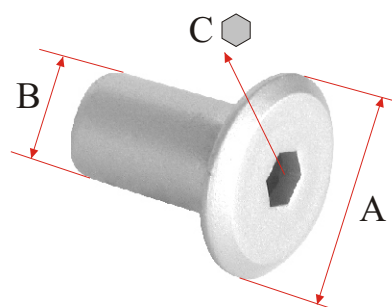
REF.	A (mm)	B (mm)	C (mm)
CHAMPIÑON ZINC	24	12.5	6

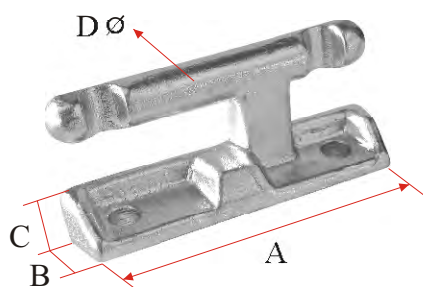



## BISAGRA COMPLETA

REF.	A (mm)	B (mm)	C (mm)
M TIR-7 ZINC	98	23	14
M TIR-7 INOX	98	23	14

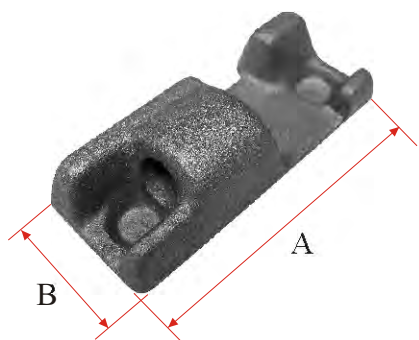

## BISAGRA COMPLETA

REF.	A (mm)	B (mm)	C (mm)
H TIR-7 BG	100	41	12
H TIR-7 BD	96	41	6

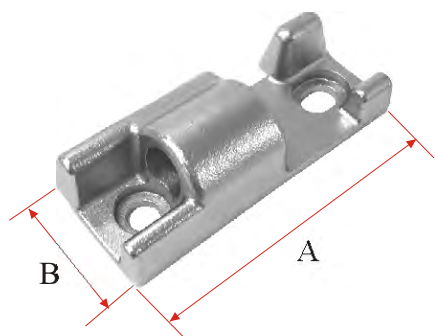

## BISAGRA COMPLETA

REF.	A (mm)	B (mm)	C (mm)
H TIR-7 INOX	94	39	8.5

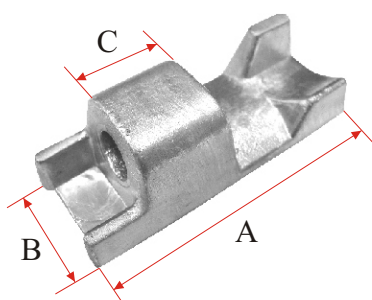

## BISAGRA COMPLETA

REF.	A (mm)	B (mm)	C (mm)
H TIR-7 ALU	100	39.5	30

**BISAGRA COMPLETA**

REF.	A (mm)	B (mm)	C (mm)
M TIR-9 ZINC	90	21	12

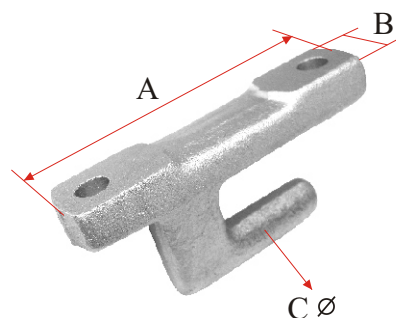

**BISAGRA COMPLETA**

REF.	A (mm)	B (mm)	C (mm)
H TIR-9 ZINC	92	27	32

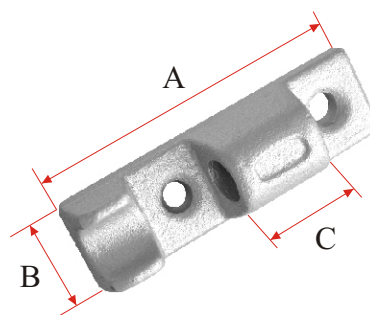

**BISAGRA COMPLETA**

REF.	A (mm)	B (mm)	C (mm)
M TIR-11 ZINC	107	24	46

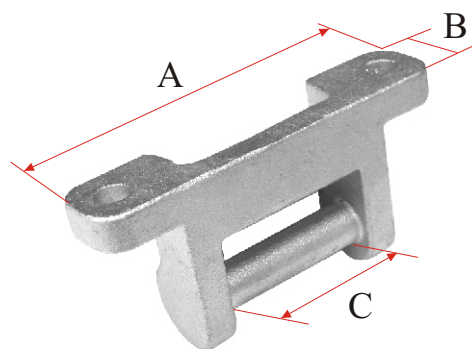

**BISAGRA COMPLETA**

REF.	A (mm)	B (mm)	C (mm)
S TIR-11	43	46	5

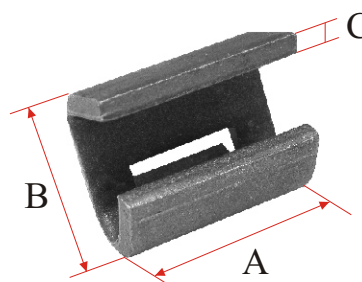

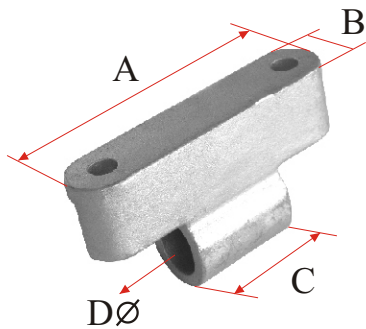

**BISAGRA COMPLETA**

REF.	A (mm)	B (mm)	C (mm)	D (mm)
H TIR-14 ZINC	99	23	39.5	20

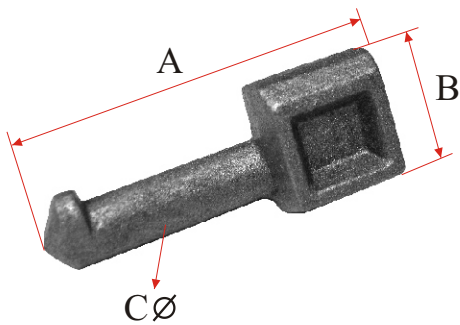

**BISAGRA COMPLETA**

REF.	A (mm)	B (mm)	C (mm)
M TIR-14	91	33	15

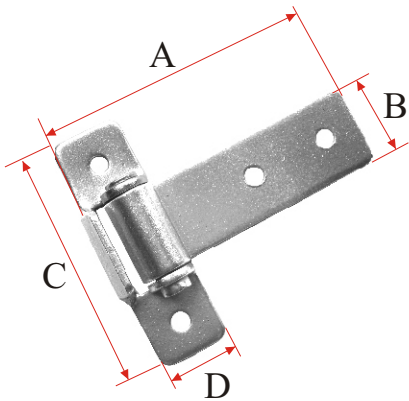

**BISAGRA DE CHAPA**

REF.	A (mm)	B (mm)	C (mm)	D (mm)
BS-21 ZINC	100	29	85	25

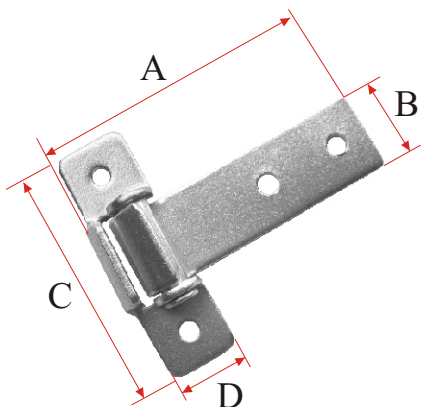

**BISAGRA DE CHAPA**

REF.	A (mm)	B (mm)	C (mm)	D (mm)
BS-22 ZINC	101	28	85	25

**BISAGRA DE CHAPA**

REF.	A (mm)	B (mm)	C (mm)	D (mm)
SICT	75	55	58	23

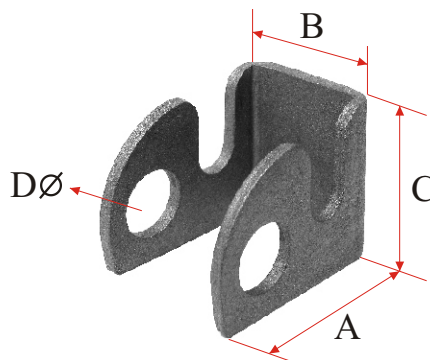

**BISAGRA DE CHAPA**

REF.	A (mm)	B (mm)	C (mm)
UCT	61	35	14

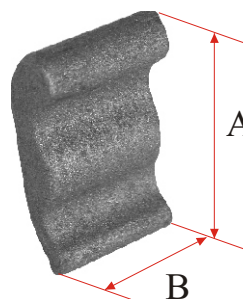

**BISAGRA DE CHAPA**

REF.	A (mm)	B (mm)	C (mm)
SSCT	215	72	28

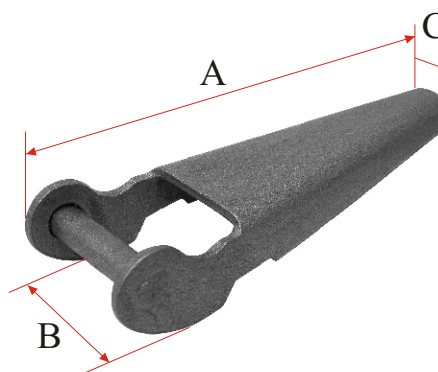

**BISAGRA DE CHAPA**

REF.	A (mm)	B (mm)	C (mm)
SSCT-C	125	70	40

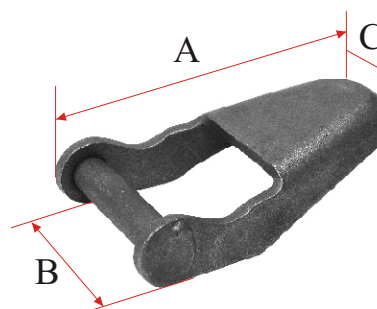



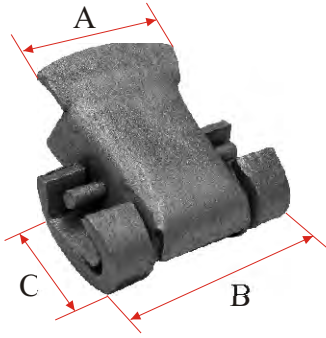

**BISAGRA DE CHAPA**

REF.	A (mm)	B (mm)	C (mm)
TIR 2 AP	70	95	55

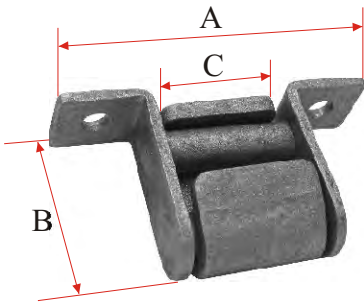

**BISAGRA DE CHAPA**

REF.	A (mm)	B (mm)	C (mm)
TIR AB	108	62	40

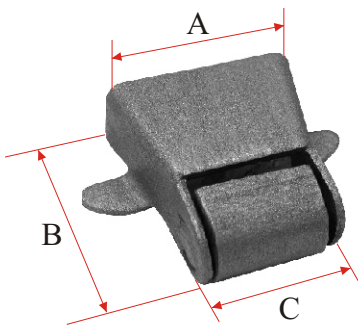

**BISAGRA DE CHAPA**

REF.	A (mm)	B (mm)	C (mm)
TIR CD	86	80	40

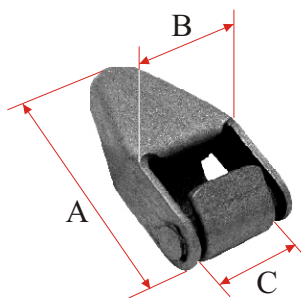

**BISAGRA DE CHAPA**

REF.	A (mm)	B (mm)	C (mm)
BS-11	84	44	31

**BISAGRA DE CHAPA**

REF.	A (mm)	B (mm)	C (mm)
BS-12	130	54	40

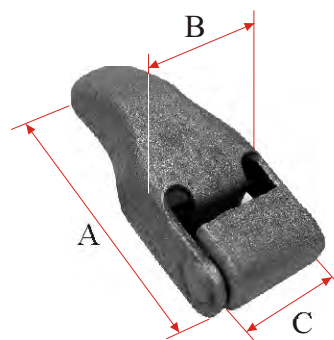
**BISAGRA DE CHAPA**

REF.	A (mm)	B (mm)	C (mm)	D (mm)
BS-20	80	28	20	3
BS-30	107	40	30	4
BS-40	141	49	40	4

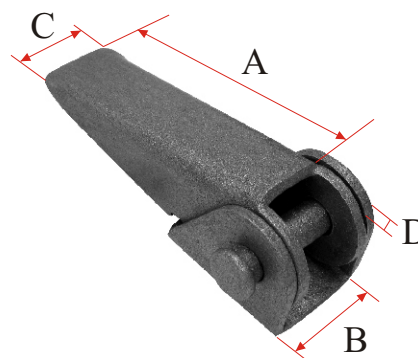

**BISAGRA DE CHAPA**

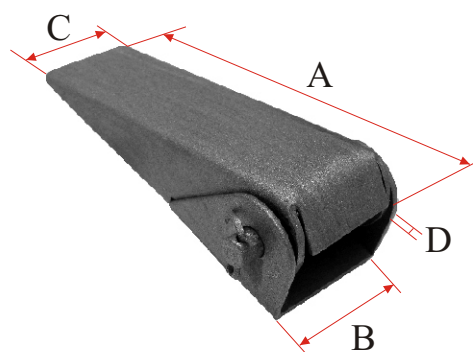
REF.	A (mm)	B (mm)	C (mm)	D (mm)
BS-1	165	60	50	3
BS-2	165	60	50	4
BS-3	155	37	33	3

**BISAGRA DE CHAPA**

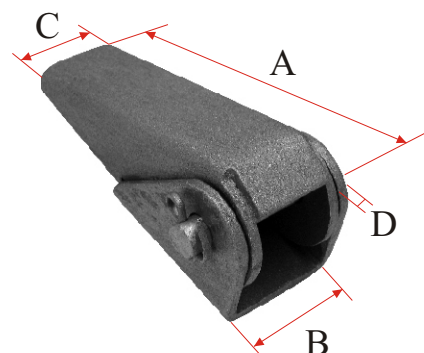
REF.	A (mm)	B (mm)	C (mm)	D (mm)
BS-4	126	45	38	3
BS-5	126	48	38	4

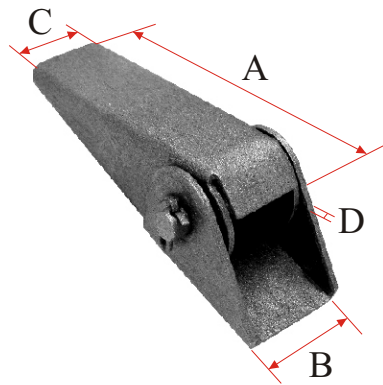



**BISAGRA DE CHAPA**

REF.	A (mm)	B (mm)	C (mm)	D (mm)
BS-6	126	45	38	3

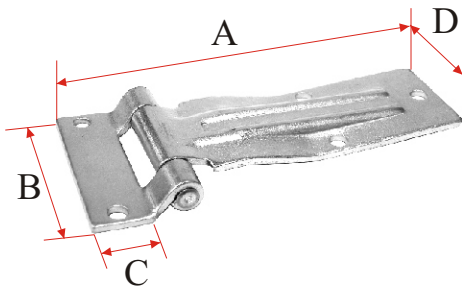

**BISAGRA DE LIBRO**

REF.	A (mm)	B (mm)	C (mm)	D (mm)
BCS-1 ZINC	185	85	25	55
BCS-1 INOX	185	85	25	55

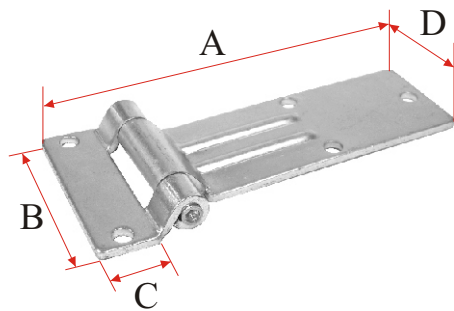

**BISAGRA DE LIBRO**

REF.	A (mm)	B (mm)	C (mm)	D (mm)
BCS-2 ZINC	180	85	25	55
BCS-2 INOX	180	85	25	55

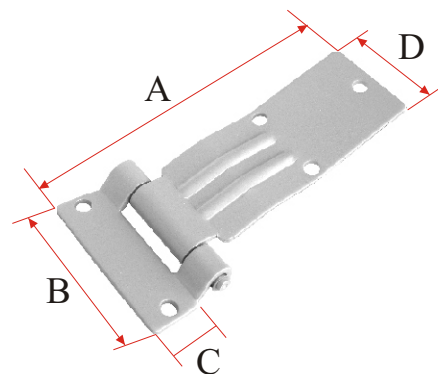

**BISAGRA DE LIBRO**

REF.	A (mm)	B (mm)	C (mm)	D (mm)
BCS-3 ZINC	180	85	25	55
BCS-3 INOX	180	85	25	55

**BISAGRA DE LIBRO**

REF.	A (mm)	B (mm)	C (mm)	D (mm)
BCS-4 ZINC	135	60	16	26

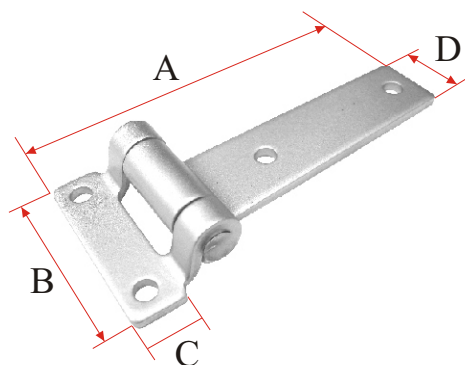

**BISAGRA DE LIBRO**

REF.	A (mm)	B (mm)	C (mm)	D (mm)
BCS-4 AC ZINC	138.5	60	19	27
BCS-4 AC INOX	138.5	60	19	27

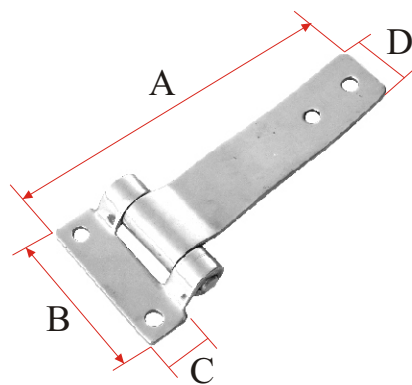

**BISAGRA DE LIBRO**

REF.	A (mm)	B (mm)	C (mm)	D (mm)
BCS-7 ZINC	275	82	83	45

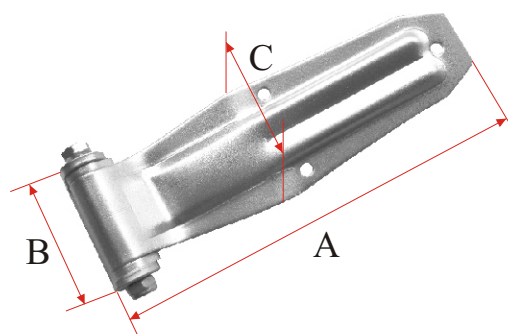

**BISAGRA DE LIBRO**

REF.	A (mm)	B (mm)	C (mm)	D (mm)
BCS-8 ZINC	320	88	82	75

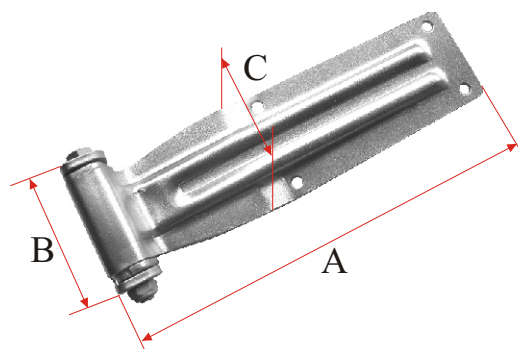

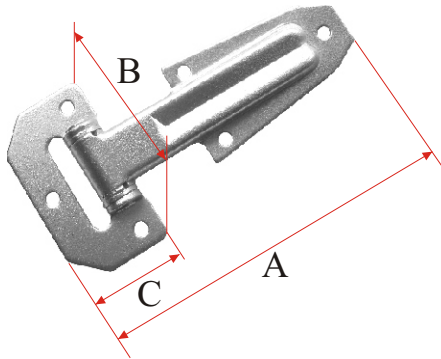

<b>BISAGRA DE LIBRO</b>				
REF.	A (mm)	B (mm)	C (mm)	D (mm)
BCS-10 ZINC	140	70	40	16

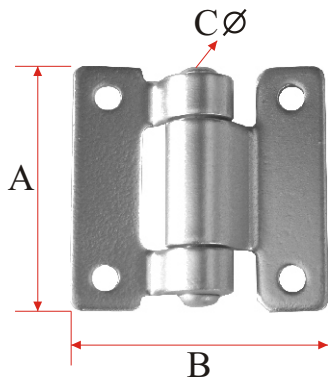

<b>BISAGRA DE LIBRO</b>			
REF.	A (mm)	B (mm)	C (mm)
BCS-11 ZINC	60	59	16

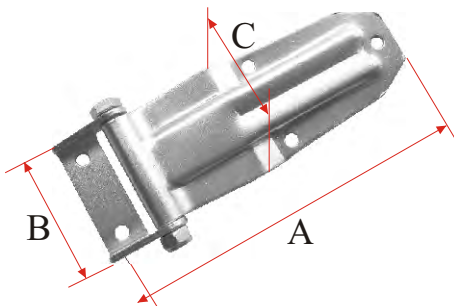

<b>BISAGRA DE LIBRO</b>				
REF.	A (mm)	B (mm)	C (mm)	D (mm)
BCS-12 ZINC	220	77	70	62

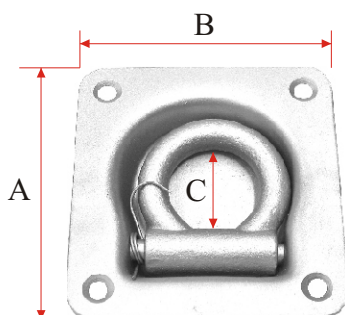

<b>ANILLA</b>			
REF.	A (mm)	B (mm)	C (mm)
AE-1 ZINC	102	95	33

**ANILLA**

REF.	A (mm)	B (mm)	C (mm)
AE-1 S/A ZINC	48	45	12

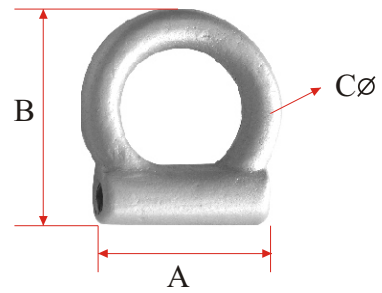

**ANILLA**

REF.	A (mm)	B (mm)	C (mm)	D (mm)
AT-1 ZINC	95	14	90	30

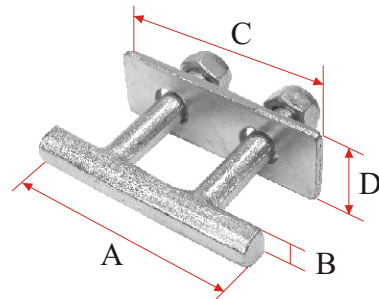

**ANILLA**

REF.	A (mm)	B (mm)	C (mm)	D (mm)
AES-2 ZINC	130	115	65	19

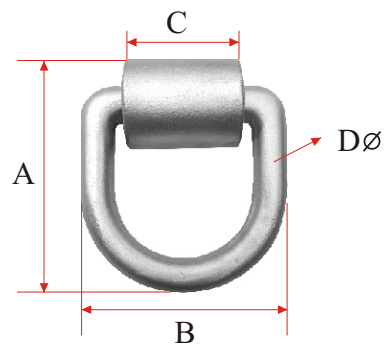

**ANILLA**

REF.	A (mm)	B (mm)	C (mm)	D (mm)
AES-1	172	128	61	26

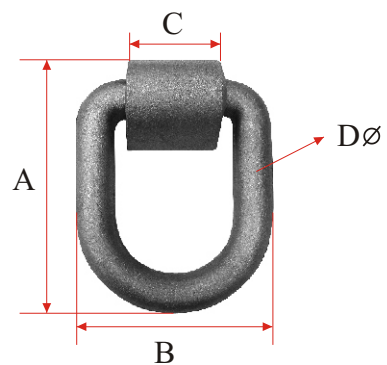

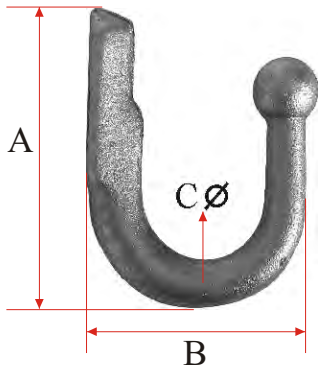

GANCHO Y PRECINTO			
REF.	A (mm)	B (mm)	C (mm)
G-1	80	60	13

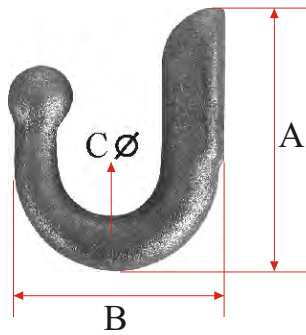

GANCHO Y PRECINTO			
REF.	A (mm)	B (mm)	C (mm)
G-2	57	57	13
G-2 ALU	55	54	12

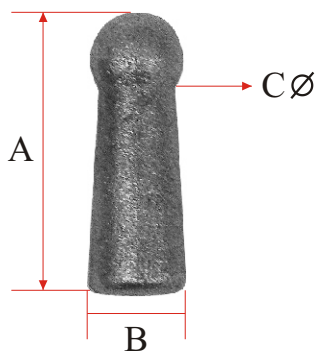

GANCHO Y PRECINTO			
REF.	A (mm)	B (mm)	C (mm)
G-3	37	13	10

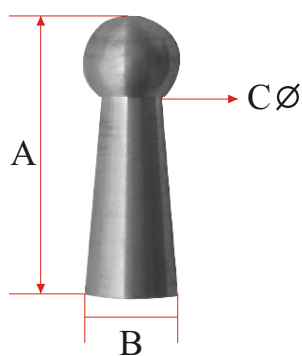

GANCHO Y PRECINTO			
REF.	A (mm)	B (mm)	C (mm)
G-3M ALU	34	11	7.5

**GANCHO Y PRECINTO**

REF.	A (mm)	B (mm)	C (mm)
G-3M	32	11	7

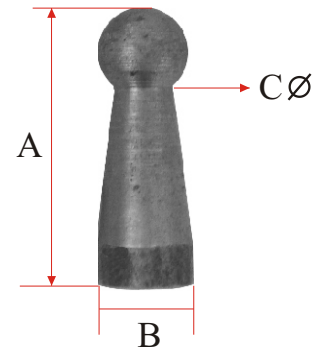

**GANCHO Y PRECINTO**

REF.	A (mm)	B (mm)	C (mm)	D (mm)
G-4	121	85	25	11
G-5	100	65	20	8

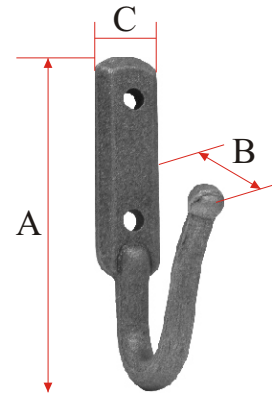

**GANCHO Y PRECINTO**

REF.	A (mm)	B (mm)	C (mm)	D (mm)
G-6	122	60	54	14
G-7	100	54	43	12
G-10	81	42	37	10

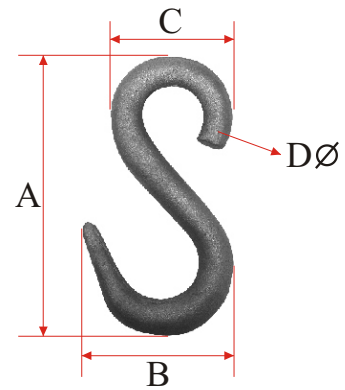

**GANCHO Y PRECINTO**

REF.	A (mm)	B (mm)	C (mm)	D (mm)
G-9	240	75	13	11

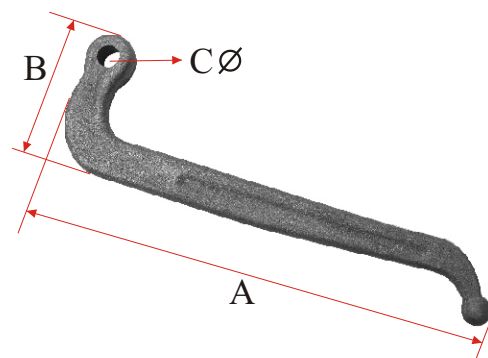



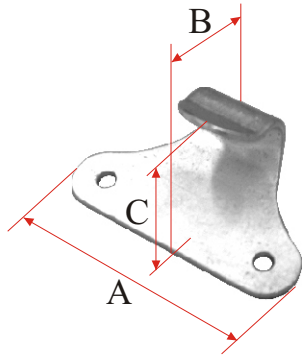

**GANCHO Y PRECINTO**

REF.	A (mm)	B (mm)	C (mm)
GH-2 ZINC	62	38	26

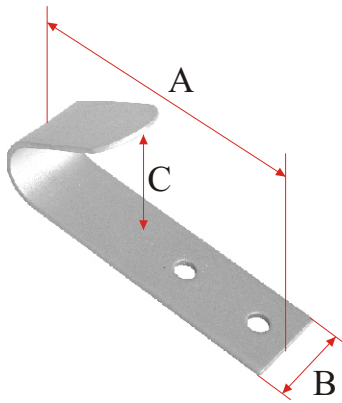

**GANCHO Y PRECINTO**

REF.	A (mm)	B (mm)	C (mm)
GH-4 ZINC	70	20	31
GH-5 ZINC	41	15	14

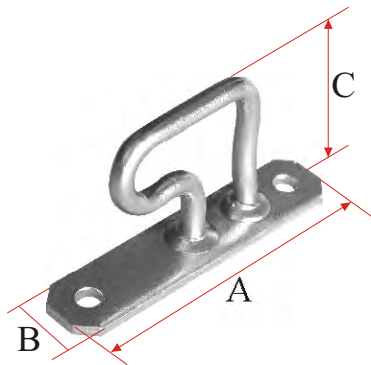

**GANCHO Y PRECINTO**

REF.	A (mm)	B (mm)	C (mm)
GH-11 ZINC	71	16	38

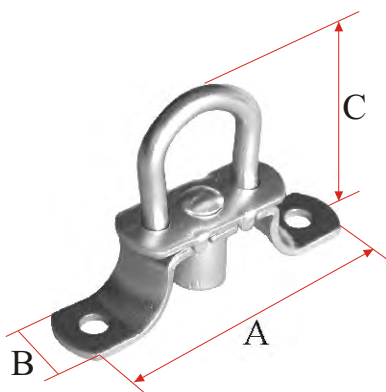

**GANCHO Y PRECINTO**

REF.	A (mm)	B (mm)	C (mm)
GH-12 ZINC	71	16	46

**GANCHO Y PRECINTO**

REF.	A (mm)	B (mm)	C (mm)
GH-13 ZINC	73	17	26

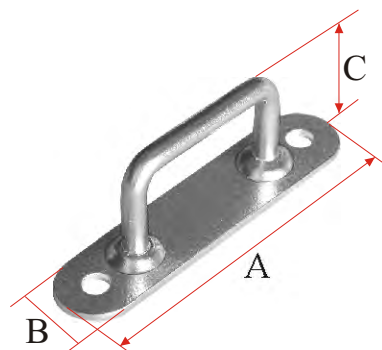

**GANCHO Y PRECINTO**

REF.	A (mm)	B (mm)	C (mm)
GH-14 ZINC	72	16	28

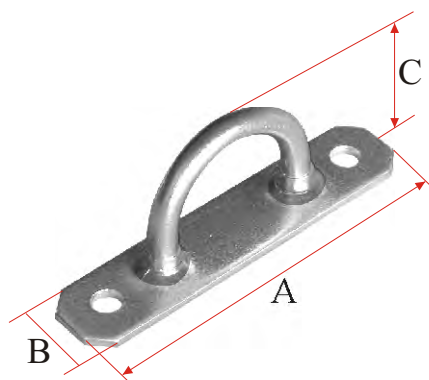

**GANCHO Y PRECINTO**

REF.	A (mm)	B (mm)	C (mm)
GH-15 ZINC	81	16	30

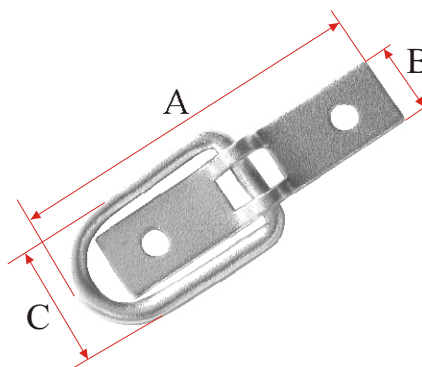

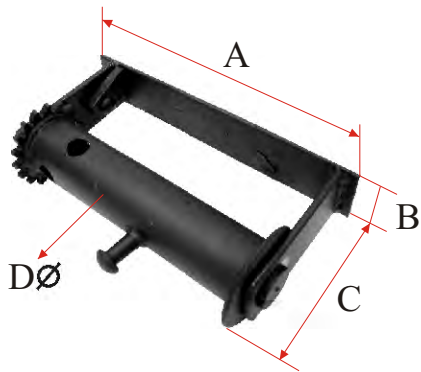

TORNO TENSOR				
REF.	A (mm)	B (mm)	C (mm)	D (mm)
TT-40 S/C	208	40	95	40

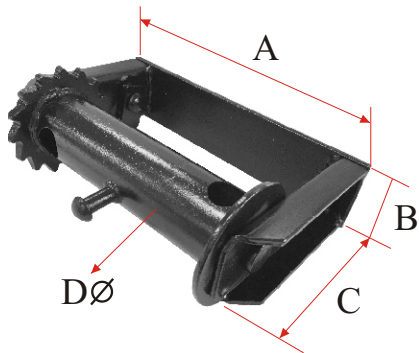

TORNO TENSOR				
REF.	A (mm)	B (mm)	C (mm)	D (mm)
TT-50 S/C	214	50	135	50

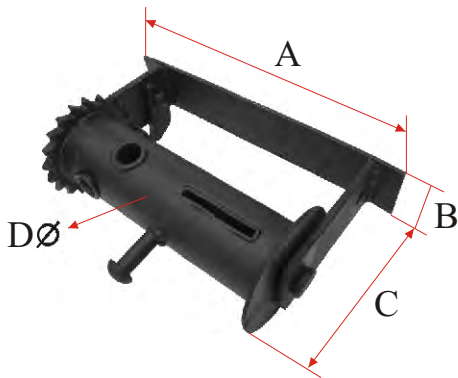

TORNO TENSOR				
REF.	A (mm)	B (mm)	C (mm)	D (mm)
TT-60 C/CE	248	50	115	60

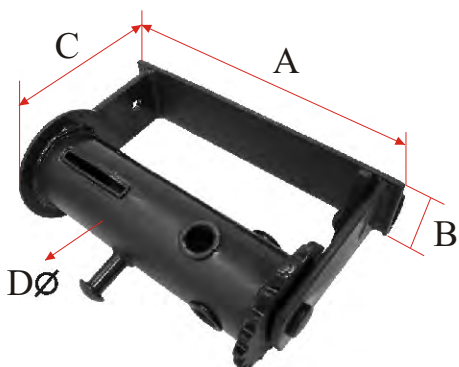

TORNO TENSOR				
REF.	A (mm)	B (mm)	C (mm)	D (mm)
TT-60 C/C DES 232		55	165	60

**TORNO TENSOR**

REF.	A (mm)	B (mm)	C (mm)	D (mm)
TT-60 C/C	250	50	150	60

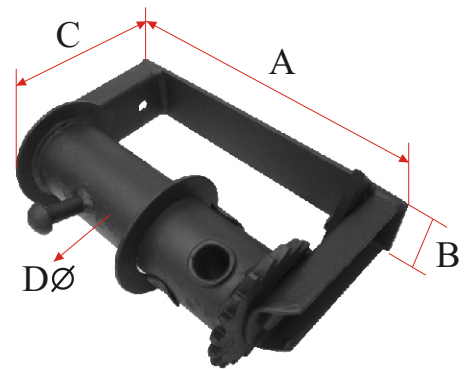
**TORNO TENSOR**

REF.	A (mm)	B (mm)	C (mm)	D (mm)
TT-48 R/F	178	90	138	48

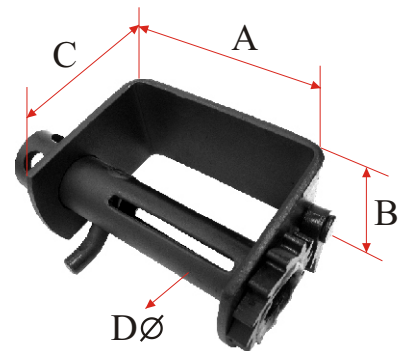

**TORNO TENSOR**

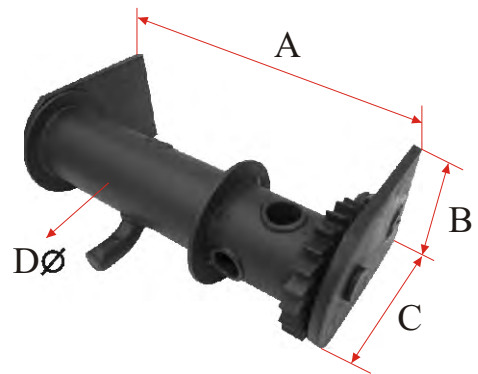
REF.	A (mm)	B (mm)	C (mm)	D (mm)
TT-60 RF	280	90	145	60

**TORNO TENSOR**

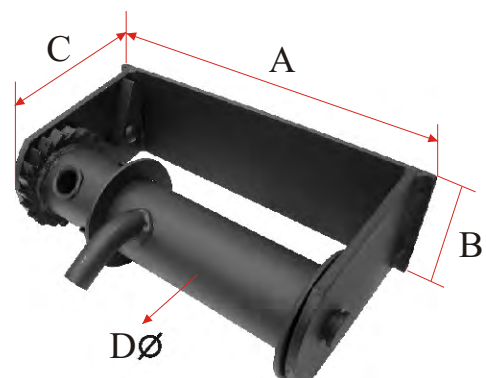
REF.	A (mm)	B (mm)	C (mm)	D (mm)
TT-60 RF/B	295	90	150	60

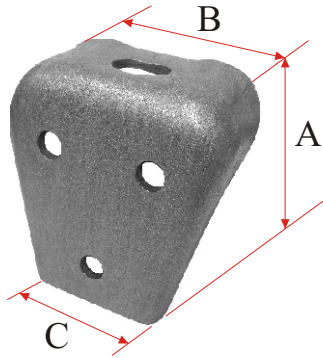



### SOPORTE DE CHASIS

REF.	A (mm)	B (mm)	C (mm)
SC-1	112	110	72

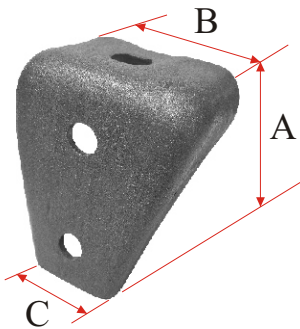

### SOPORTE DE CHASIS

REF.	A (mm)	B (mm)	C (mm)
SC-2	90	81	41

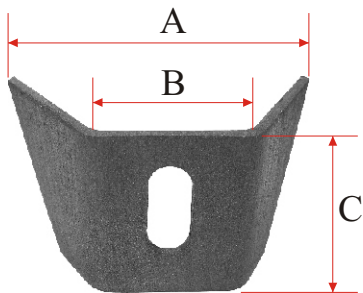

### SOPORTE DE CHASIS

REF.	A (mm)	B (mm)	C (mm)
SC-3	124	45	60

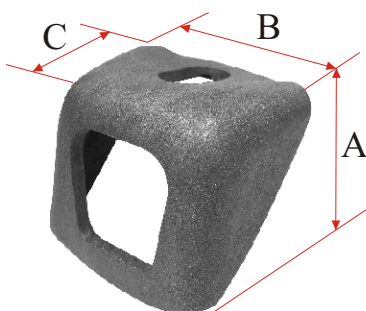

### SOPORTE DE CHASIS

REF.	A (mm)	B (mm)	C (mm)
SC-4	68	74	56

**SOPORTE DE CHASIS**

REF.	A (mm)	B (mm)	C (mm)	D (mm)
SC-6 ZINC	120	60	14	10

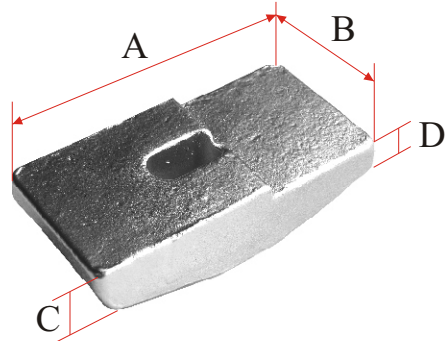

**SOPORTE DE CHASIS**

REF.	A (mm)	B (mm)	C (mm)	D (mm)
SC-7 ZINC	124	50	15	13

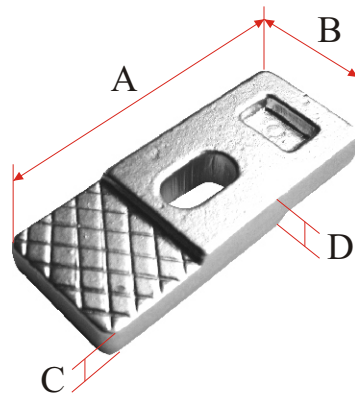

**SOPORTE DE CHASIS**

REF.	A (mm)	B (mm)	C (mm)	D (mm)
SC-10 ZINC	80	35	27	10
SC-11 ZINC	53	30	21	10

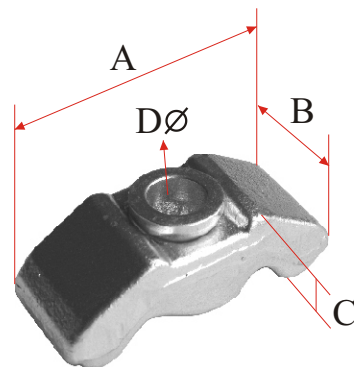

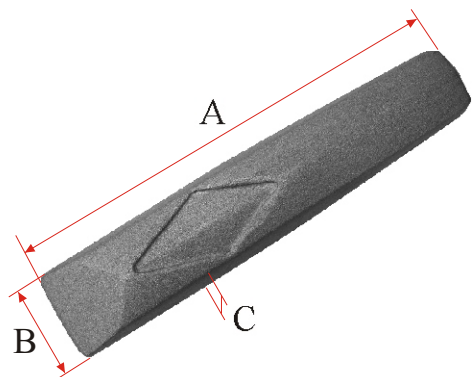

### PILAR CÓNICO Y CUÑA DE LLANTA

REF.	A (mm)	B (mm)	C (mm)
P-0	390	60	32
P-1	290	60	31
P-2	240	50	25
P-3	205	40	25

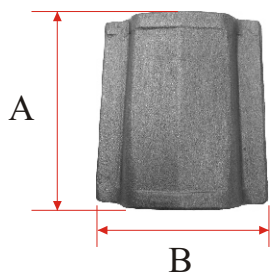

### PILAR CÓNICO Y CUÑA DE LLANTA

REF.	A (mm)	B (mm)
AP-0	129	110
AP-1	115	105
AP-2	96	84
AP-3	85	77

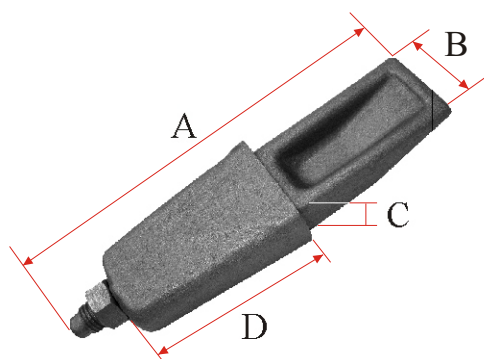

### PILAR CÓNICO Y CUÑA DE LLANTA

REF.	A (mm)	B (mm)	C (mm)	D (mm)
CU-1	300	70	30	130
CU-2	300	70	25	130
CU-3	325	90	30	160
CU-4	380	110	30	175

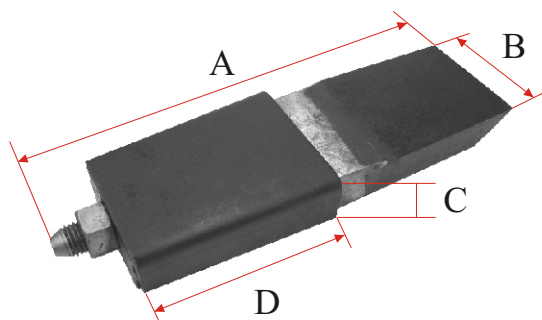

### PILAR CÓNICO Y CUÑA DE LLANTA

REF.	A (mm)	B (mm)	C (mm)	D (mm)
CLL-1	310	60	25	120
CLL-2	365	70	25	130
CLL-3	330	90	25	160
CLL-4	330	90	25	130
CLL-5	360	110	25	160
CLL-6	330	70	30	140
CLL-7	335	90	30	130
CLL-8	360	110	30	160

**SOPORTE DE ALETA**

REF.	A (mm)	B (mm)	C (mm)
SRA-1 ZINC	352	40	40

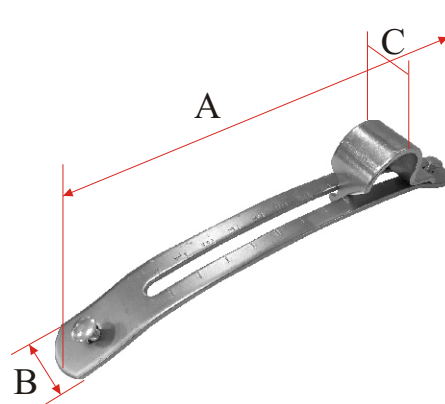

**SOPORTE DE ALETA**

REF.	A (mm)	B (mm)	C (mm)	D (mm)
SRA-3 ZINC	760	102	77	41.5

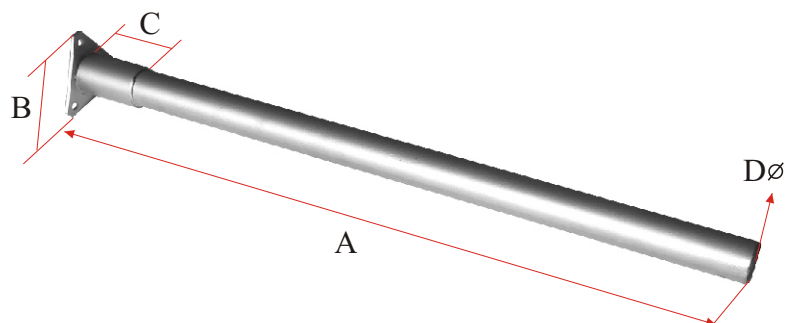

**SOPORTE DE ALETA**

REF.	A (mm)	B (mm)	C (mm)	D (mm)
SRA-5	530	75	40	42

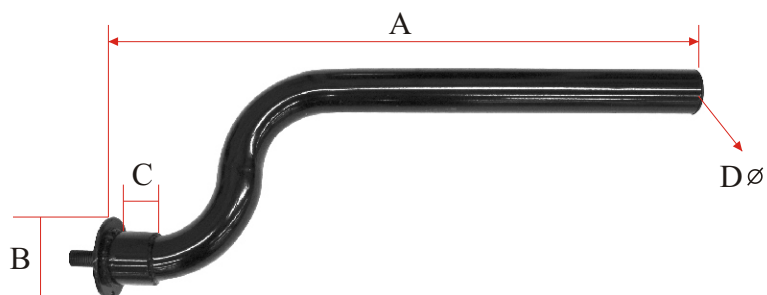



## SOPORTE DE RUEDA

REF.	A (mm)	B (mm)	C (mm)
ER-1	208	190	145

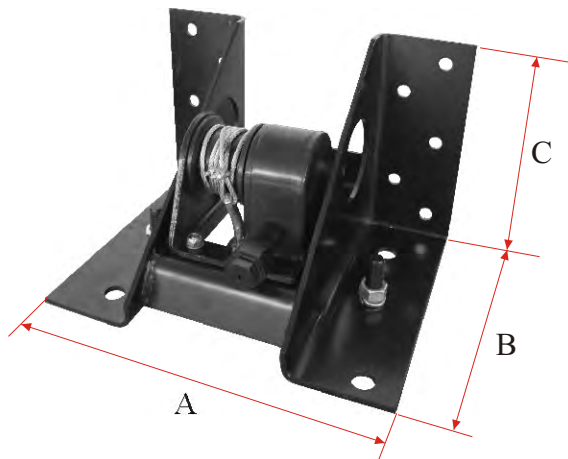
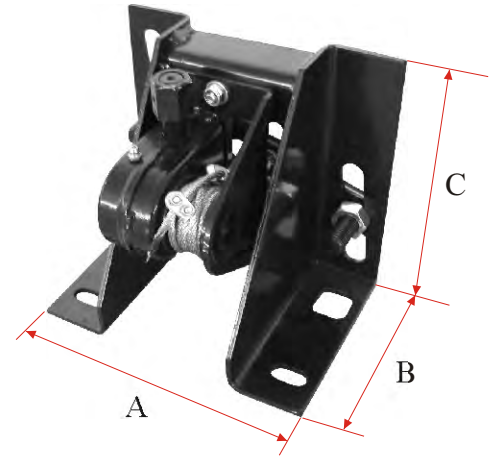
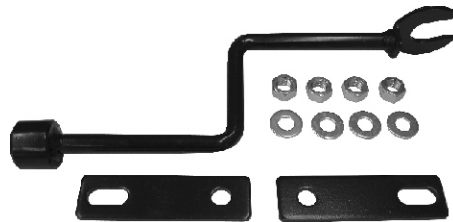

## SOPORTE DE RUEDA

REF.	A (mm)	B (mm)	C (mm)
ER-2	330	255	220

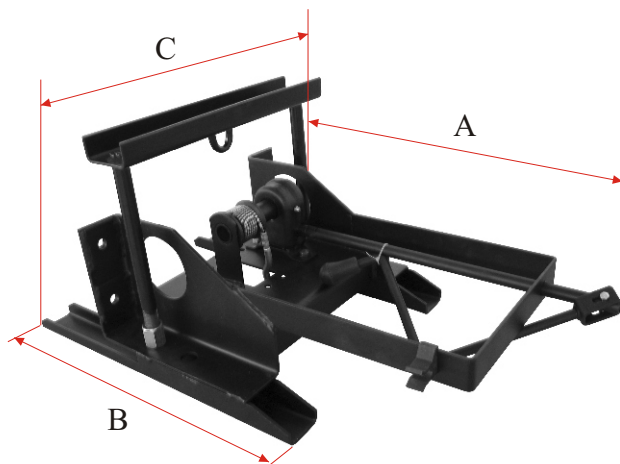

## SOPORTE DE RUEDA

REF.	A (mm)	B (mm)	C (mm)
ER-3.2	770	392	490

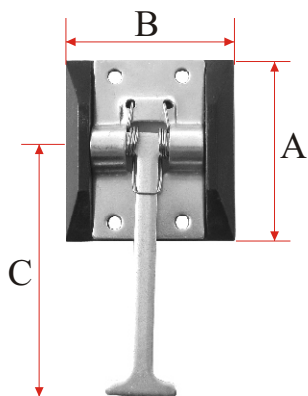

### RETENEDOR DE PUERTA

REF.	A (mm)	B (mm)	C (mm)
RPM-2 ZINC	65	55	92
RPM-2 INOX	65	55	92

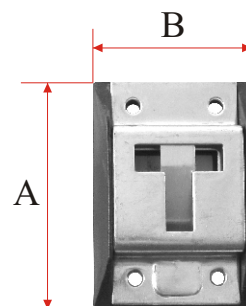

### RETENEDOR DE PUERTA

REF.	A (mm)	B (mm)
RPH-2 ZINC	81	50
RPH-2 INOX	81	50

### RETENEDOR DE PUERTA

REF.	A (mm)	B (mm)	C (mm)
RP-10 ZINC	540	415	25

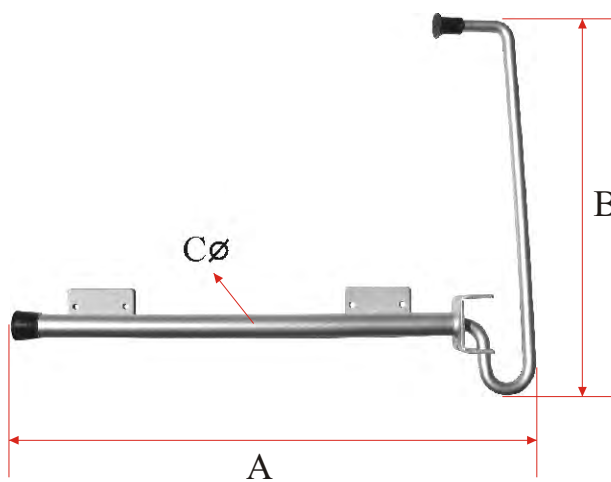

### RETENEDOR DE PUERTA

REF.	A (mm)	B (mm)	C (mm)
RP-11 ZINC	480	285	28

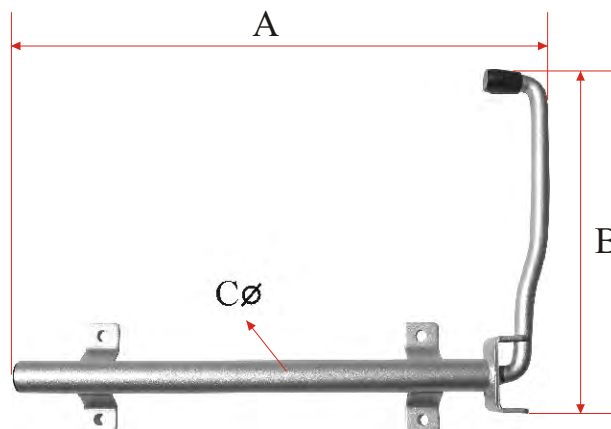

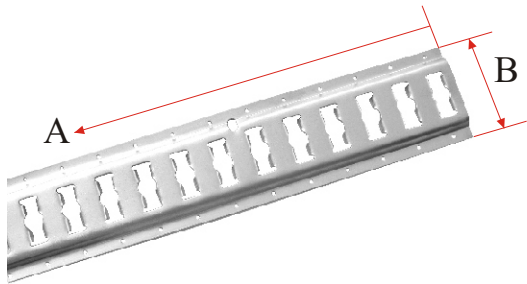

## SISTEMA DE CARGA

REF.	A (mm)	B (mm)
TSC-10 ZINC	3000	80

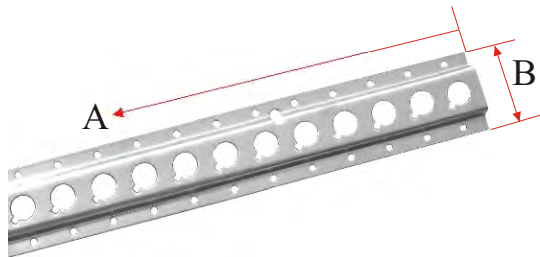

## SISTEMA DE CARGA

REF.	A (mm)	B (mm)
TSC-11 ZINC	3000	130

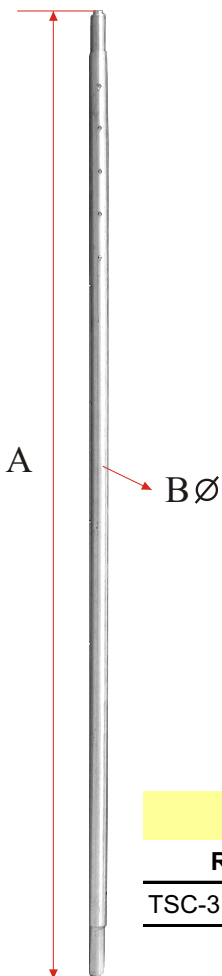

## SISTEMA DE CARGA

REF.	A (mm)	B (mm)
TSC-3 ZINC	2260-2660	42

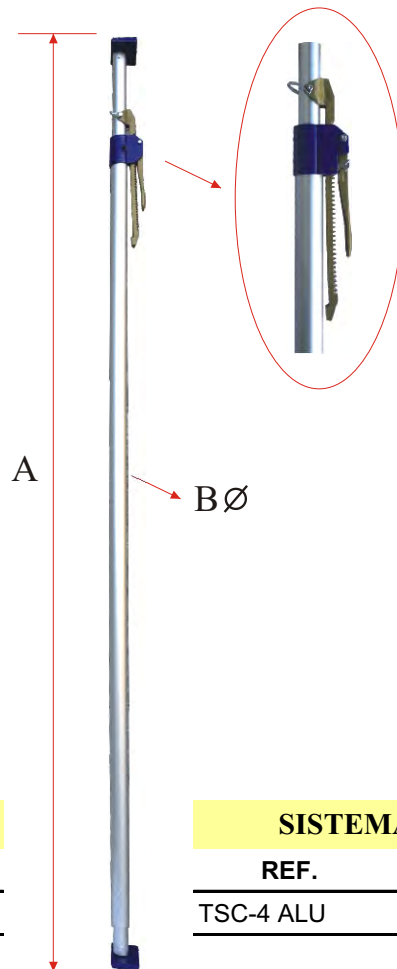

## SISTEMA DE CARGA

REF.	A (mm)	B (mm)
TSC-4 ALU	2300-2960	42

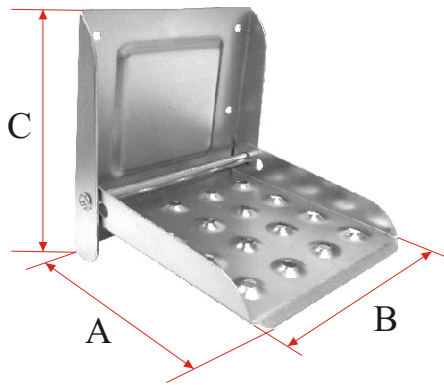

ESCALERA			
REF.	A (mm)	B (mm)	C (mm)
ESC-0 ZINC	187	170	188

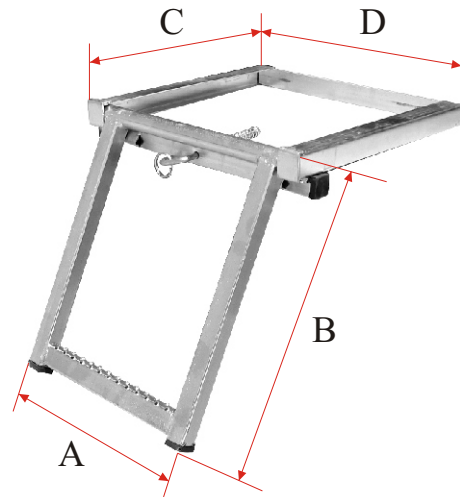

ESCALERA				
REF.	A (mm)	B (mm)	C (mm)	D (mm)
ESC-1 ZINC	290	365	350	360

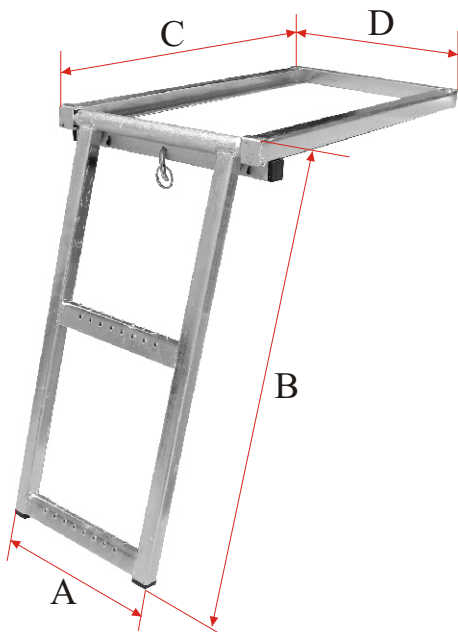

ESCALERA				
REF.	A (mm)	B (mm)	C (mm)	D (mm)
ESC-2 ZINC	270	625	650	350

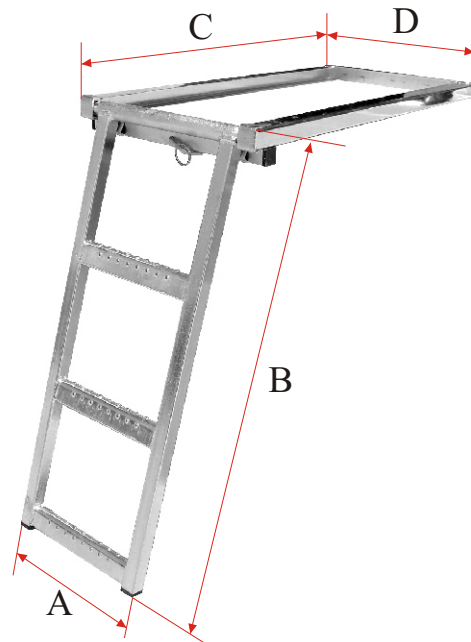

ESCALERA				
REF.	A (mm)	B (mm)	C (mm)	D (mm)
ESC-3 ZINC	270	730	750	350

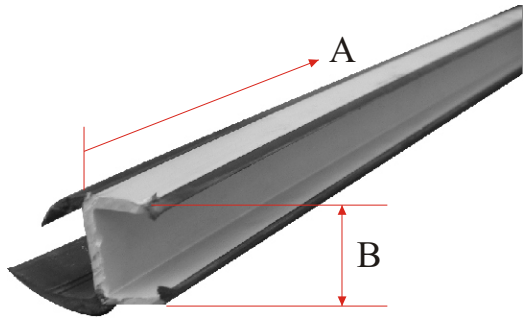

## PERFIL MIXTO

REF.	A (mm)	B (mm)
Perfil-1 PVC	5000	20
Perfil-3 PVC	5000	30
Perfil-5 PVC	5000	25

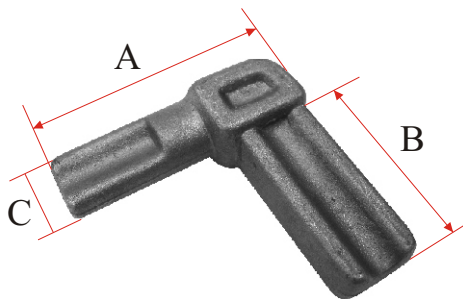

## ENGARCE DE ARQUILLO

REF.	A (mm)	B (mm)	C (mm)
EA-2	80	47	27

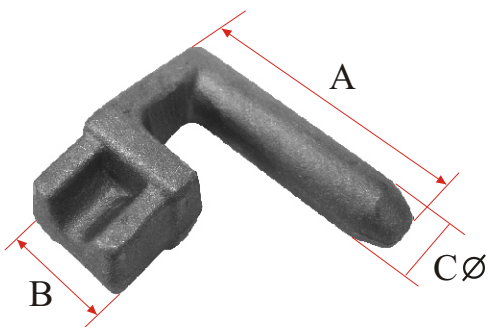

## ENGARCE DE ARQUILLO

REF.	A (mm)	B (mm)	C (mm)
EA-3	80	31	19

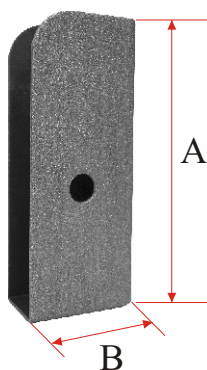

## CAJETÍN DE TABLA

REF.	A (mm)	B (mm)	C (mm)	D (mm)
CJ-1 ZINC	130	50	26	2
CJ-15	130	50	26	2

**SOPORTES PARA DEPÓSITO DE AGUA**

REF.	A (mm)	B (mm)
SBD-1 Z	450	120

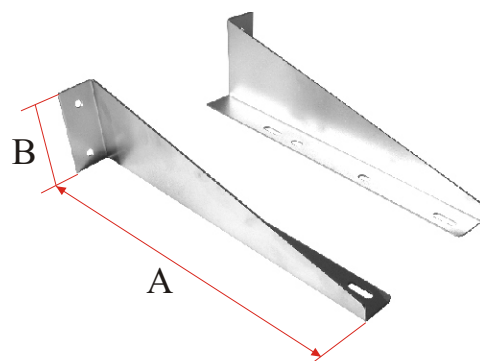

**DEPÓSITO DE AGUA**

REF.	A (mm)	B (mm)
BD-1	450	340

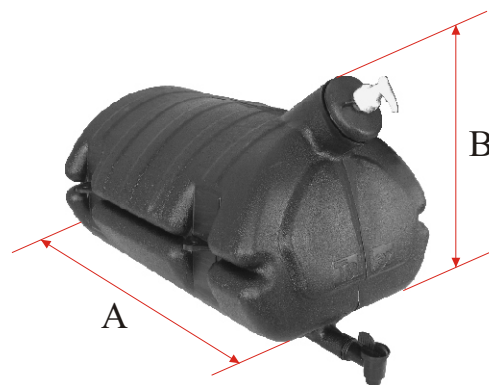

**SOPORTE ANTIEMPOTRAMIENTO**

REF.	A (mm)	B (mm)
PLAC-1 ZINC	730	50

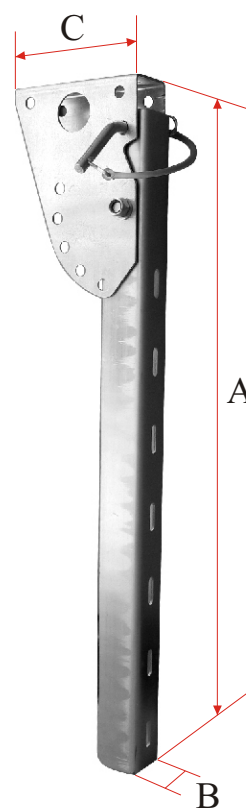

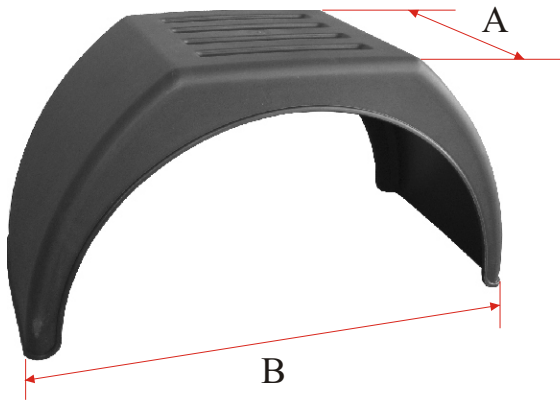

## GUARDABARRO

REF.	A (mm)	B (mm)
GBP-1	450	880
GBP-1 G	520	1060

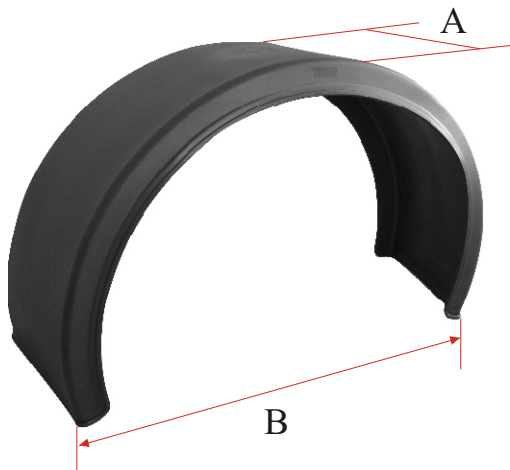

## GUARDABARRO

REF.	A (mm)	B (mm)
GB-1	410	860
GB-2	450	860
GB-3	500	1000
GB-4	550	1100
GB-5	435	1300
GB-6	670	1340

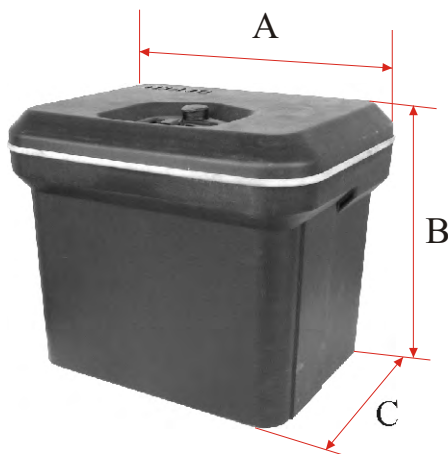

## CAJA DE HERRAMIENTA

REF.	A (mm)	B (mm)	C (mm)
CAJAH 410	410	330	340
CAJAH 500	500	350	400
CAJAH 600	600	400	500
CAJAH 800	800	500	500

**TACO DE GOMA**

REF.	A (mm)	B (mm)	C (mm)
TG-0	115	90	75
TG-1	195	80	80
TG-2	240	90	80
TG-3	350	100	100

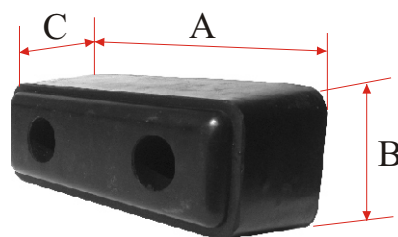
**TACO DE GOMA**

REF.	A (mm)	B (mm)	C (mm)
TG-4	490	80	80

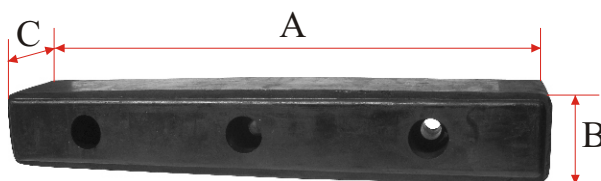
**CAJA EXTINTOR C/VENTANA 9 KG**

REF.	A (mm)	B (mm)	C (mm)
CAJA EX-3	310	675	250





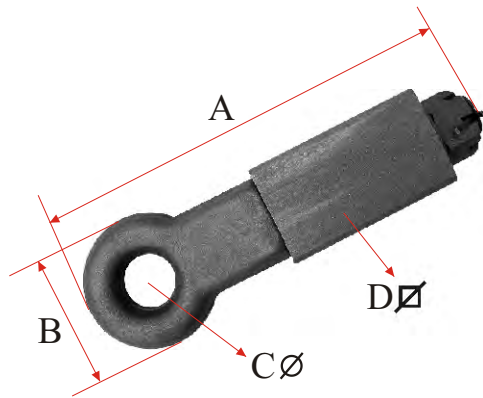

ACC.AGRÍCOLA				
REF.	A (mm)	B (mm)	C (mm)	D (mm)
TLH-50	315	100	40	50
TLH-60	315	100	40	60
TLH-70	315	100	40	70
TLH-80	315	100	40	80

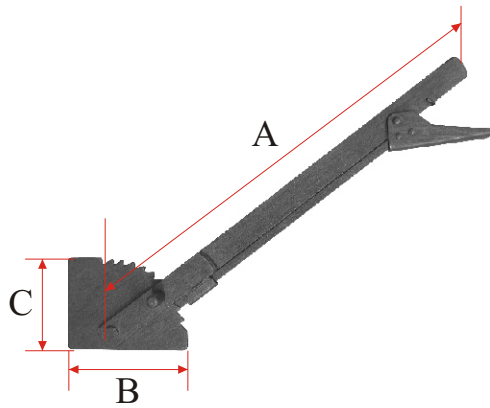

ACC.AGRÍCOLA				
REF.	A (mm)	B (mm)	C (mm)	D (mm)
PLF-1	545	145	110	6

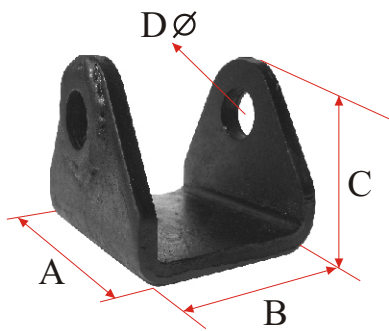

ACC.AGRÍCOLA				
REF.	A (mm)	B (mm)	C (mm)	D (mm)
SBO-1	100	94	88	25

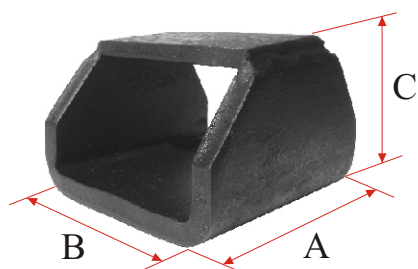

ACC.AGRÍCOLA			
REF.	A (mm)	B (mm)	C (mm)
SBR-1	100	97	69

### ACC.AGRÍCOLA

REF.	A (mm)	B (mm)	C (mm)	M
AB-1	157	102	15	16
AB-2	160	106	16	18
AB-3	180	106	16	18
AB-4	180	106	20	20

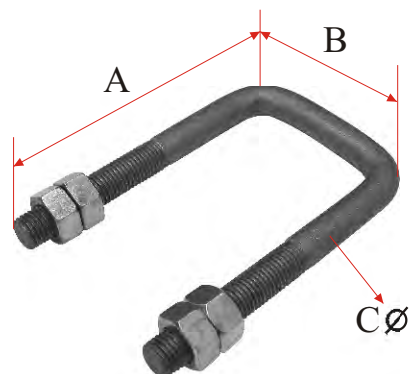

### ACC.AGRÍCOLA

REF.	A (mm)	B (mm)	C (mm)	D (mm)
AR-1 M20 ZINC	99	67	18	20

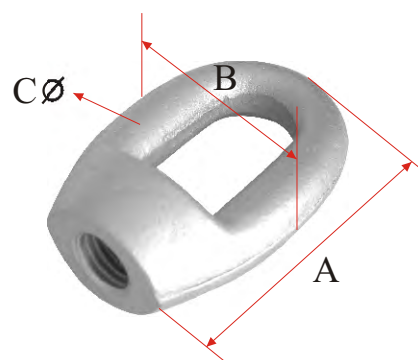

### ACC.AGRICOLA

REF.	A (mm)	B (mm)	C (mm)
GR-1 M20 ZINC	136	56	20

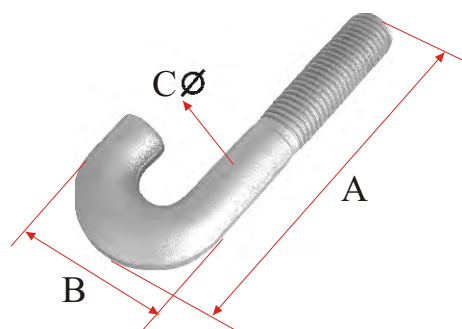

### ACC.AGRICOLA

REF.	A (mm)	B (mm)	C (mm)
BB-1 ZINC	120	90	22
BB-2 ZINC	140	105	24

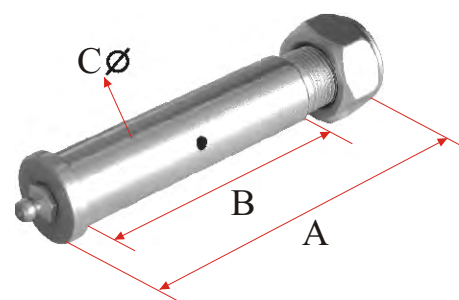

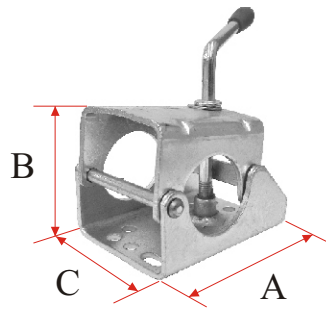

**ABRAZADERA JOCKEY**

REF.	A (mm)	B (mm)	C (mm)
ABRJ-48	130	60	53
ABRJ-60	130	100	100

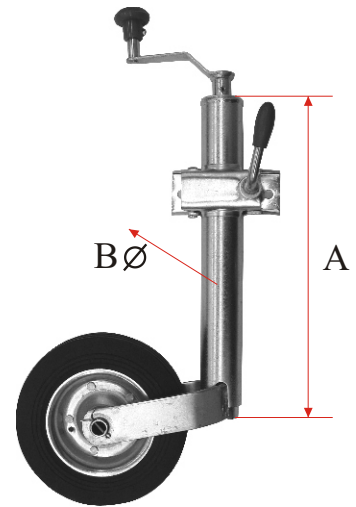

**RUEDA JOCKEY**

REF.	A (mm)	B (mm)
RJ-48	385	48

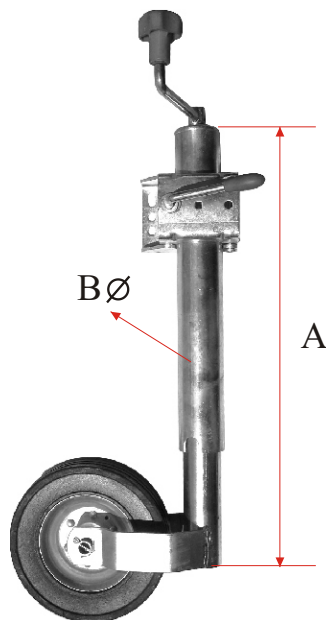

**RUEDA JOCKEY**

REF.	A (mm)	B (mm)
RJ-60	460	60

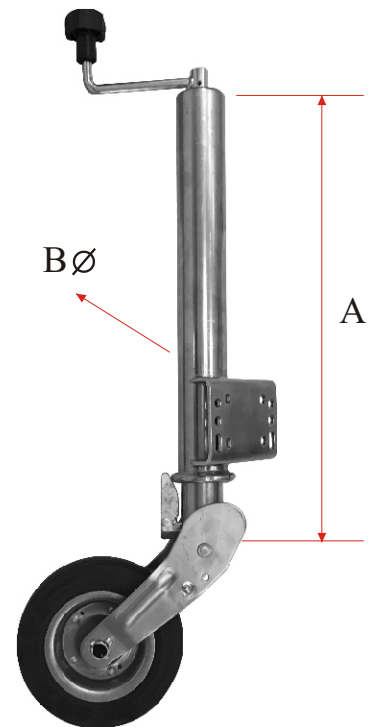

**RUEDA JOCKEY AUTO.**

REF.	A (mm)	B (mm)
RJ-60 AU	540	60

**MOZO DE APOLLO**

REF.	A (mm)	B (mm)
MZ-1	50	500-800
MZ-2	60	500-800
MZ-3	70	500-800
MZ-4	80	500-800

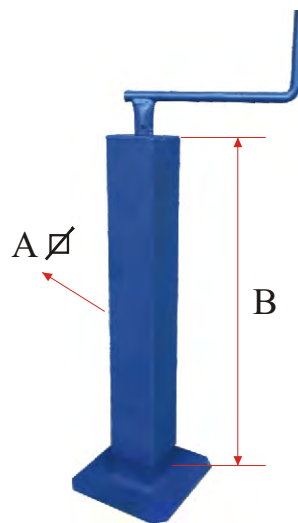
**CABRESTANTE**

REF.	A (mm)	B (mm)	C (mm)	D (mm)
CBT-1	155	118	82	120
CBT-2	185	140	88	150

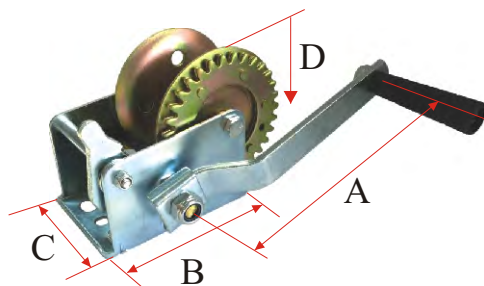
**CABRESTANTE**

REF.	A (mm)	B (mm)	C (mm)	D (mm)
CBT-3	205	185	120	165

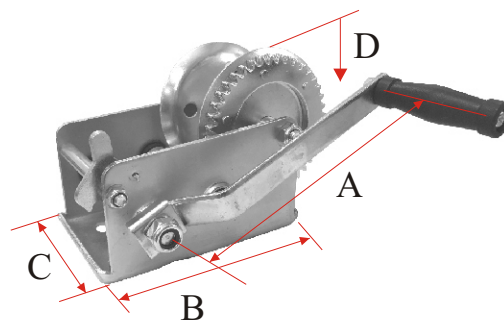
**CABEZA DE ENGANCHE**

REF.	AxB (mm)	KGS
CE-1	50x50	750
CE-2	60x60	750
CE-3	70x70	750
CE-4	50x50	1300
CE-5	60x60	1300



## COMBINACIÓN DE PIEZAS

CIERRES	UÑAS
C-2 ZINC C-2 C-12 ZINC C-12	U-2 ZINC U-2 U-6 ZINC U-6 U-7 ZINC U-7
C-3 ZINC C-3 C-13 ZINC C-13	U-3 ZINC U-3 U-9 ZINC U-9
C-4 ZINC C-4 C-14 ZINC C-14 C-5 ZINC C-5	U-4 ZINC U-4
C-7 ZINC C-7	U-2 ZINC U-2 U-6 ZINC U-6 U-7 ZINC U-7 U-8 ZINC U-8
C-8 ZINC C-8	U-6 ZINC U-6 U-7 ZINC U-7 U-8 ZINC U-8
C-9 ZINC C-9	U-9 ZINC U-9
C-15 ZINC CH-30	U-30
CH-31	UH-31
CH-10 ZINC CH-10.2 ZINC	UH-10 ZINC UH-11 ZINC
CH-10.3 ZINC	UH-10.3 ZINC

CIERRES	UÑAS
CH-21 ZINC	UH-13 ZINC UH-12 ZINC
CH-14 ZINC CH-15 ZINC	UH-15 ZINC UH-14 ZINC
CH-20 ZINC	UH-20.2 ZINC UH-20 ZINC
CH-8 CH-3	UH-3/8"
CH-32 ZINC	UH-32 ZINC
CH-35 ZINC	UH-35 ZINC
CH-4	UH-4

HEMBRAS	MACHOS
CB-1	UB-1
CR-1	H-5
CR-2	H-10
CR-5	H-5
CR-6	H-10
CR-6 ALU	H-16 ALU
CRH-6	HH-10
H-1	M-2
H-10	M-5
H-13	M-6 ; M-8
H-15	M-5
H-16 ZINC	M-3
H-2	M-3
H-3	M-4
H-40	M-40
H-41	M-41 ZINC
H-5	M-1
H-5G	M-1
H-6	M-6
H-7	M-8
H-7	M-8 G